

Compact Type Parallel Style Air Gripper

Ø 8, Ø 12, Ø 16, Ø 20

RoHS

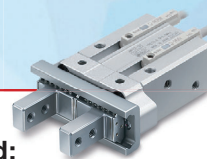

New

- A single acting type has been added.
- Made-to-order options have been added:
 - ① With positioning pins on the lateral mounting surface
 - ② Lateral auto switch mounting

Downsizing is possible without changes to the gripping point range. (Ø 20 → Ø 16)

Overall length

Max. **21.7** mm shorter

102.7 mm → 81 mm

Thickness

Max. **7.6** mm shorter

33.6 mm → 26 mm

Weight

Max. **180** g lighter

420 g → 240 g



* When comparing the Ø 25 of the MHZ2 and the Ø 20 of the JMHZ2

High rigidity and precision are achieved by integrating the guide and finger.

With high-precision linear guide

Repeatability: **±0.01** mm

A linear guide of higher rigidity and precision is used.

Higher rigidity

(Compared with the same size of the existing MHZ2)



JMHZ2 Series



CAT.EUS20-262B-UK

Compact Type Parallel Style Air Gripper *JMHZ2 Series*

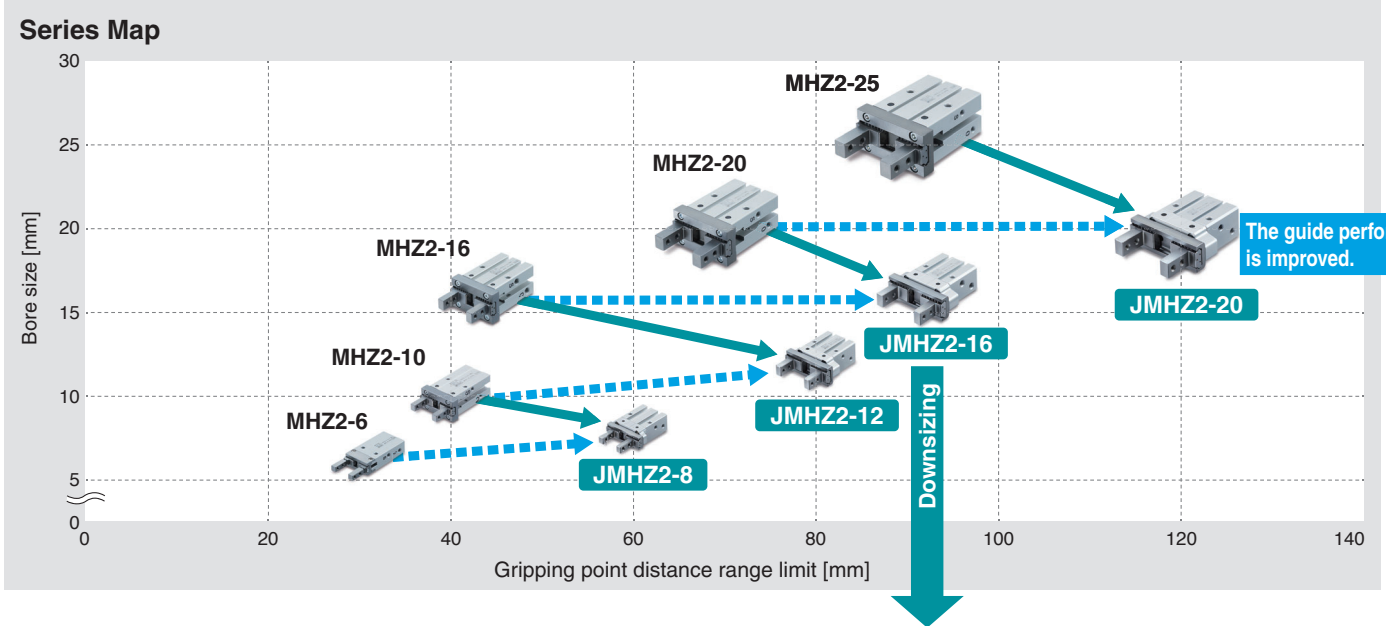

Downsizing

The cylinder can be downsized by one bore size without reducing the linear guide performance.

Bore size [mm]	
MHZ2	JMHZ2
10	8
16	12
20	16
25	20

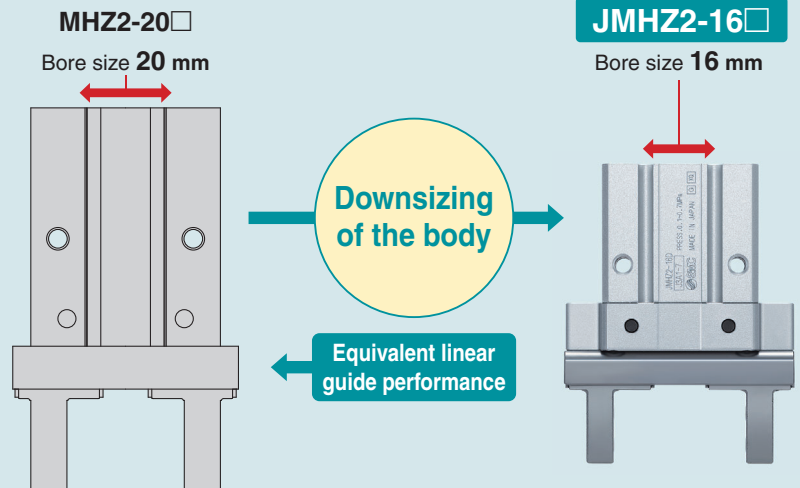

Compact and lightweight

Overall length reduction [mm]

Bore size	MHZ2	JMHZ2	Reduction
8	57	46.8 Double acting	10.2
		50.6 Single acting	6.4
12	67.3	52 Double acting	15.3
		57.5 Single acting	9.8
16	84.8	65.5 Double acting	19.3
		73 Single acting	11.8
20	102.7	81 Double acting	21.7
		91 Single acting	11.7

Thickness reduction [mm]

Bore size	MHZ2	JMHZ2	Reduction
8	16.4	13	3.4
12	23.6	17	6.6
16	27.6	20	7.6
20	33.6	26	7.6

Weight reduction [g]

Bore size	MHZ2	JMHZ2	Reduction
8	55	31 Double acting	24
		35 Single acting	20
12	115	62 Double acting	53
		72 Single acting	43
16	230	128 Double acting	102
		142 Single acting	88
20	420	240 Double acting	180
		270 Single acting	150

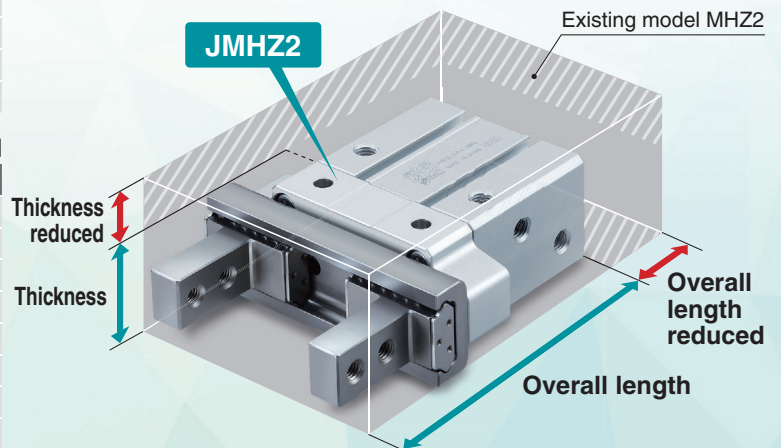

The guide performance is improved. Higher rigidity

- A linear guide equivalent to that of a cylinder one bore size larger is used.
- Higher opening/closing stroke

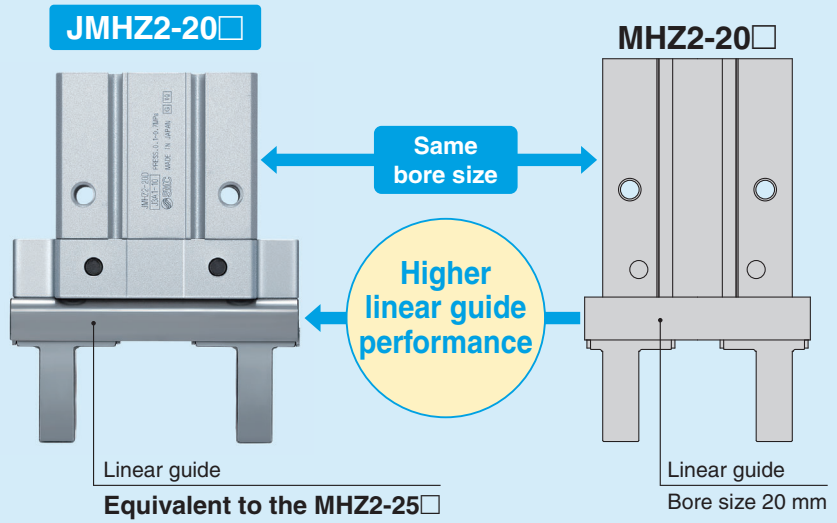

Linear guide

Linear guide	Model
Equivalent to MHZ2-10D	→ JMHZ2-8D
Equivalent to MHZ2-16D	→ JMHZ2-12D
Equivalent to MHZ2-20D	→ JMHZ2-16D
Equivalent to MHZ2-25D	→ JMHZ2-20D

Longer gripping point

A longer gripping point can be used with a cylinder one bore size smaller.

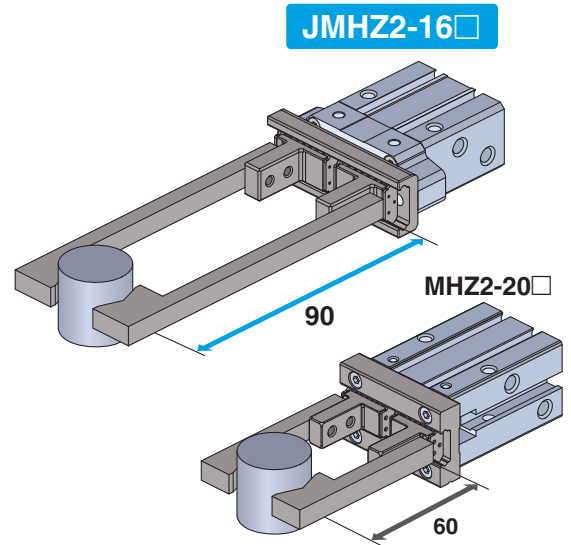
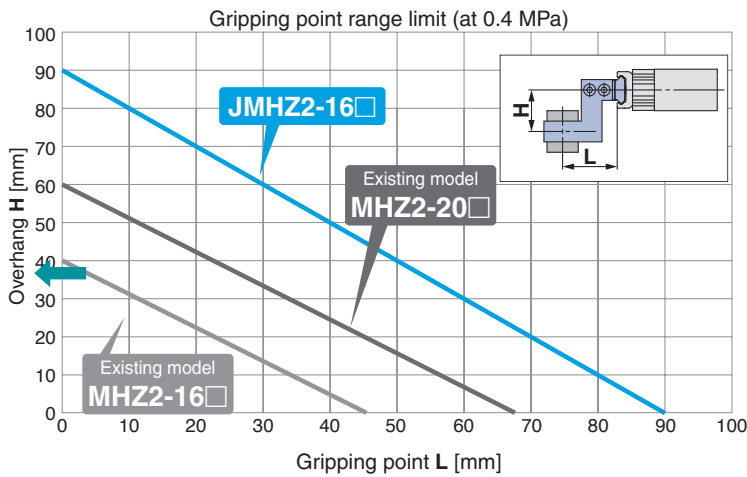

New Single acting

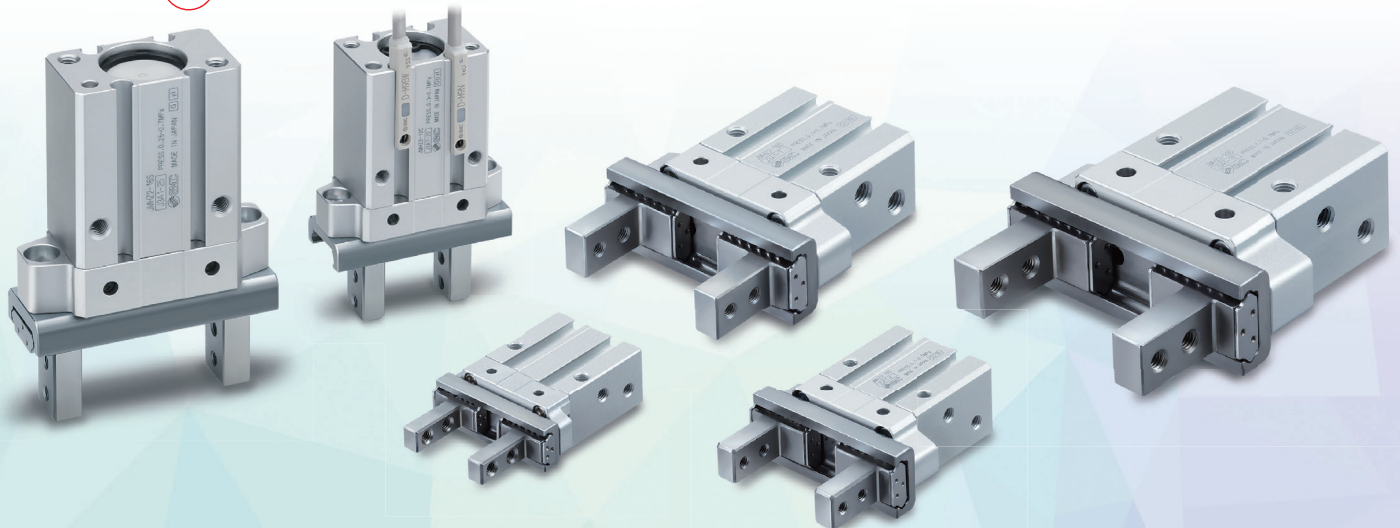

High precision

Improved remounting accuracy
Knock positioning pin hole

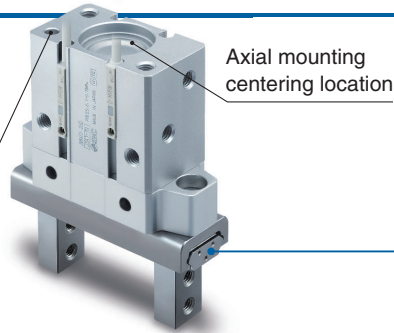

With high-precision linear guide
Repeatability: ± 0.01 mm

Linear guide

Model	Linear guide
JMHZ2-8□	Equivalent to the MHZ2-10□
JMHZ2-12□	Equivalent to the MHZ2-16□
JMHZ2-16□	Equivalent to the MHZ2-20□
JMHZ2-20□	Equivalent to the MHZ2-25□

High degree of mounting flexibility

Can be mounted 3 ways, from 2 directions

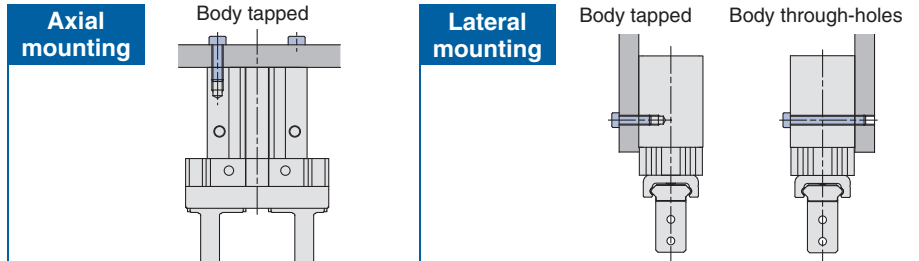

Finger options

Basic (Tapped in opening/closing direction)

Side tapped mounting

Through-holes in opening/closing direction

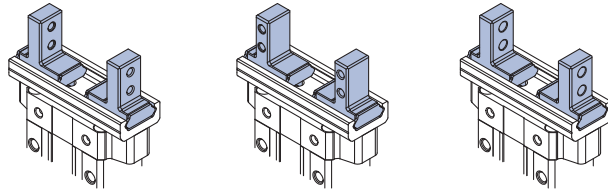

New Positioning pins are provided.

Configured for easier maintenance
(Made to order:
Refer to page 20 for details.)

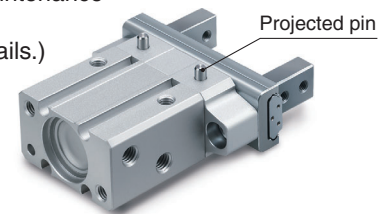

Compact auto switches are mountable.

Solid state auto switch
D-M9□

Solid state auto switch

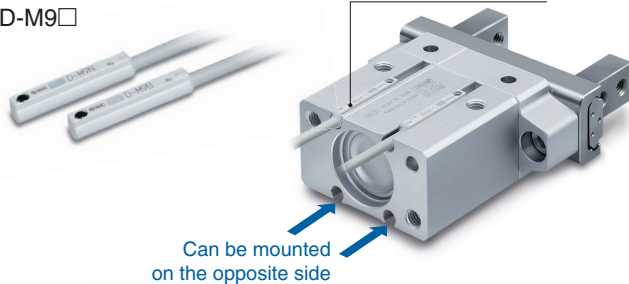

New The auto switch can be mounted from the side.

The auto switch can be mounted even when the head side is blocked.
(Made to order: Refer to page 21 for details.)

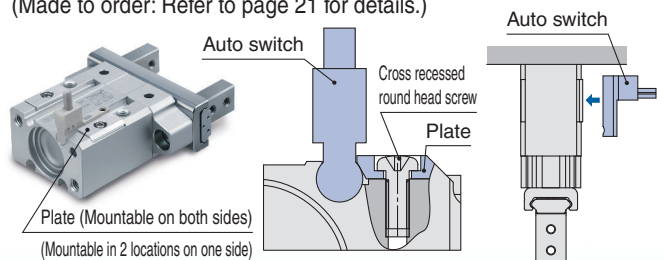

Series Variations

Series	Bore size [mm]	Action	Opening/Closing stroke (Both sides) [mm]	Mounting orientation	Finger option
Compact type JMHZ2 	8	Double acting Single acting	4	· Axial mounting · Lateral mounting	· Basic (Tapped in opening/closing direction) · Side tapped mounting · Through-holes in opening/closing direction
	12		6		
	16		10		
	20		14		

CONTENTS

Model Selection	p. 4
How to Order	p. 9
Specifications	p. 10
Construction	p. 11
Dimensions	p. 12
Auto Switch Installation Examples and Mounting Positions	p. 16

Prior to Use: Auto Switch Connections and Examples	p. 19
Made-to-Order Individual Specifications	
① With Positioning Pins on the Lateral Mounting Surface (-X6900)	p. 20
② Lateral Auto Switch Mounting (-X7460)	p. 21
Specific Product Precautions	p. 22
Safety Instructions	Back cover

JMHZ2 Series Model Selection

Model Selection

Selection Procedure

Step 1 Check the effective gripping force.

Step 2 Check the gripping point.

Step 3 Check the external force on fingers.

Step 1 Check the gripping force.

Check the conditions.

Calculate the required gripping force.

Select the model from gripping force graph.

Example

Workpiece mass:
0.1 kg

Gripping method:
External gripping

Guidelines for the selection of the gripper with respect to workpiece mass

- Although conditions differ according to the workpiece shape and the coefficient of friction between the attachments and the workpiece, select a model that can provide a gripping force of at least 10 to 20 times*¹ greater than the workpiece weight.
- *1 For further details, refer to the model selection illustration.

- Further allowance should be provided when great acceleration or impact is expected during workpiece transfer.

Example) For setting the gripping force to be at least 20 times greater than the workpiece weight:
Required gripping force = 0.1 kg x 20 x 9.8 m/s² ≈ 19.6 N or more

Gripping point:
30 mm

Operating pressure:
0.6 MPa

JMHZ2-12D External Gripping Force

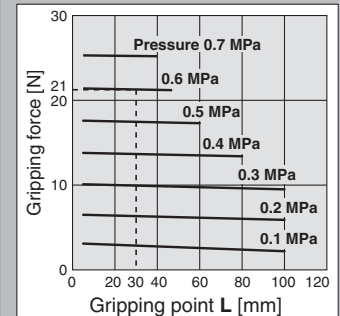

- When the **JMHZ2-12D** is selected
A gripping force of 21 N is obtained from the intersection point of gripping point L = 30 mm and a pressure of 0.6 MPa.
- The gripping force is 21 times greater than the workpiece weight, and therefore satisfies a gripping force setting value of 20 times or more.

Model Selection Illustration

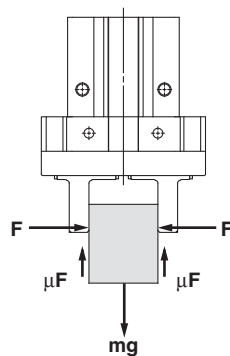

“Gripping force at least 10 to 20 times greater than the workpiece weight”

“At least 10 to 20 times greater than the workpiece weight” recommended by SMC is calculated with a margin of “a” = 4, which allows for impacts that occur during normal transportation, etc.

When $\mu = 0.2$	When $\mu = 0.1$
$F = \frac{mg}{2 \times 0.2} \times 4$	$F = \frac{mg}{2 \times 0.1} \times 4$
$= 10 \times mg$	$= 20 \times mg$

10 x Workpiece weight

20 x Workpiece weight

- * • Even in cases where the coefficient of friction is greater than $\mu = 0.2$, for reasons of safety, select a gripping force which is at least 10 to 20 times greater than the workpiece weight, as recommended by SMC.
- If high acceleration, or impact forces are encountered during motion, a further margin should be considered.

When gripping a workpiece as in the figure to the left, and with the following definitions,

F: Gripping force [N]

μ : Coefficient of friction between the attachments and the workpiece

m: Workpiece mass [kg]

g: Gravitational acceleration (= 9.8 m/s²)

mg: Workpiece weight [N]

the conditions under which the workpiece will not drop are

$$2 \times \mu F > mg$$

Number of fingers

and therefore,

$$F > \frac{mg}{2 \times \mu}$$

With “a” representing the margin,

“F” is determined by the following formula:

$$F = \frac{mg}{2 \times \mu} \times a$$

JMHZ2 Series

Model Selection

Step 1 Check the effective gripping force: JMHZ2 Series, Double Acting

External gripping state

- Indication of effective gripping force

The gripping force shown in the graphs to the right represents the gripping force of one finger when all fingers and attachments are in contact with the workpiece.

F = One finger thrust

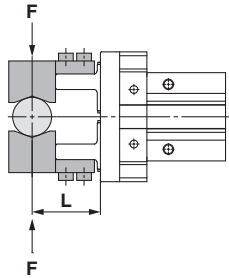

Internal gripping state

- Indication of effective gripping force

The gripping force shown in the graphs to the right represents the gripping force of one finger when all fingers and attachments are in contact with the workpiece.

F = One finger thrust

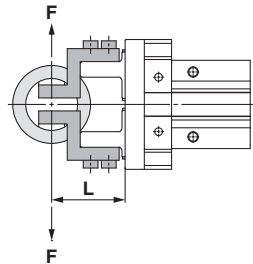

External Gripping Force

JMHZ2-8D

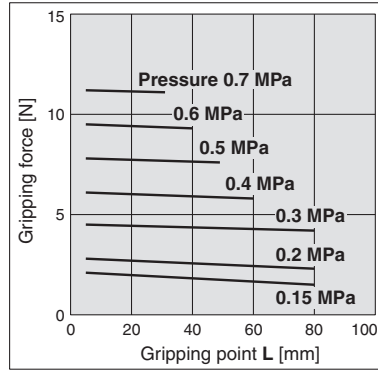

JMHZ2-12D

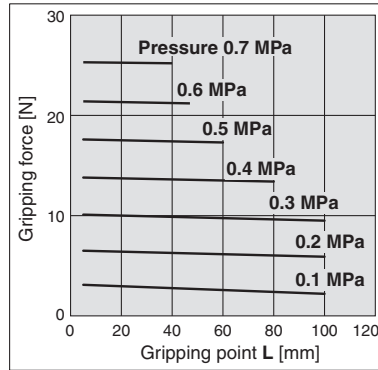

JMHZ2-16D

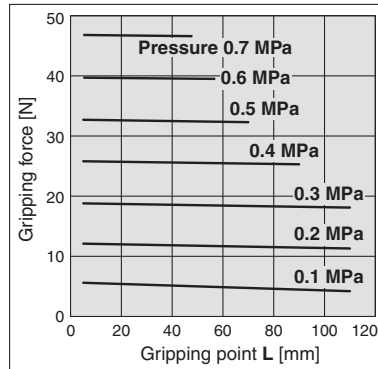

JMHZ2-20D

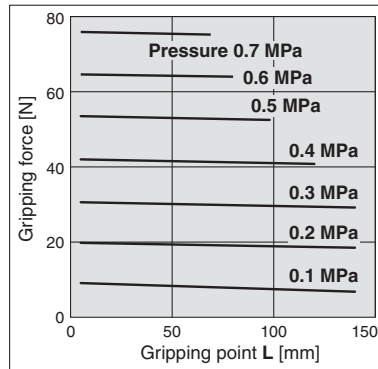

Internal Gripping Force

JMHZ2-8D

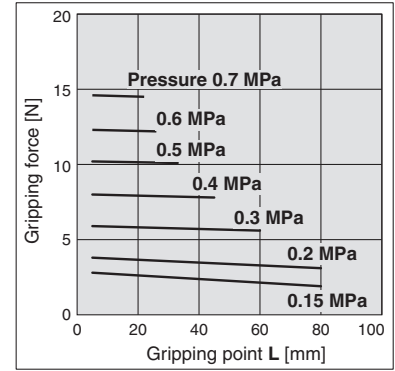

JMHZ2-12D

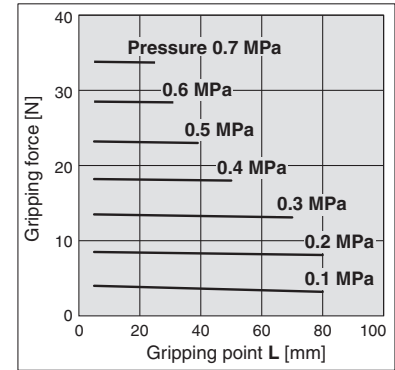

JMHZ2-16D

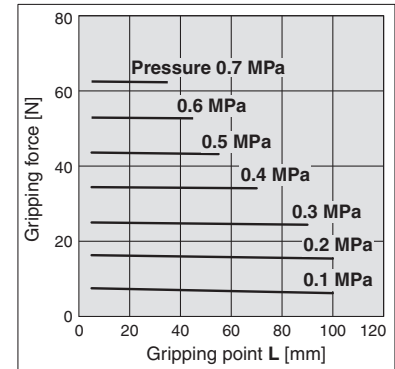

JMHZ2-20D

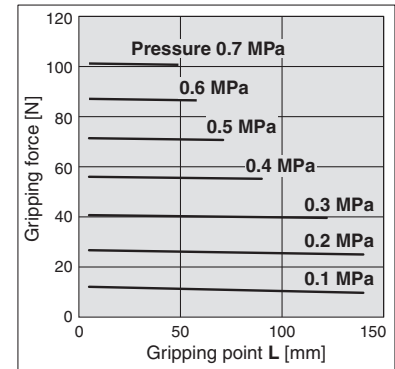

Step 1 Check the effective gripping force: JMHZ2 Series, Single Acting

External gripping state

- Indication of effective gripping force
The gripping force shown in the graphs to the right represents the gripping force of one finger when all fingers and attachments are in contact with the workpiece.
- F** = One finger thrust

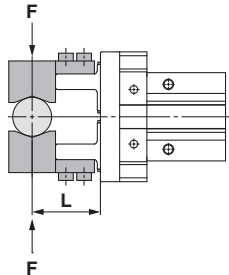

Internal gripping state

- Indication of effective gripping force
The gripping force shown in the graphs to the right represents the gripping force of one finger when all fingers and attachments are in contact with the workpiece.
- F** = One finger thrust

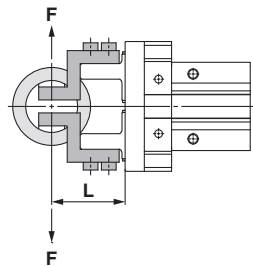

External Gripping Force

JMHZ2-8S

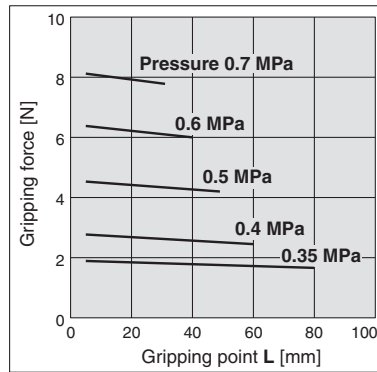

JMHZ2-12S

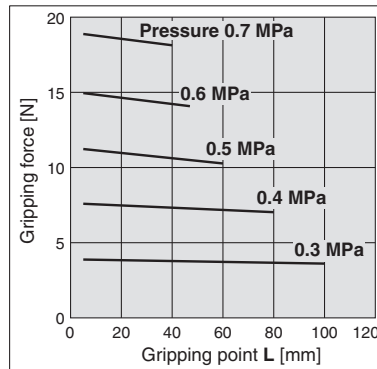

JMHZ2-16S

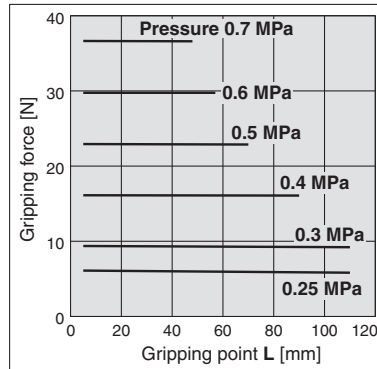

JMHZ2-20S

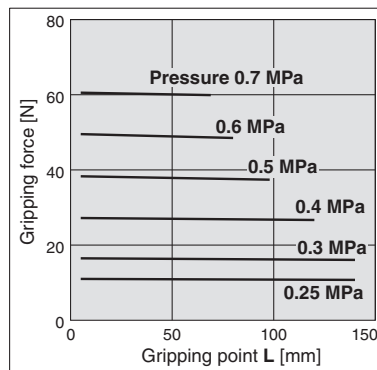

Internal Gripping Force

JMHZ2-8C

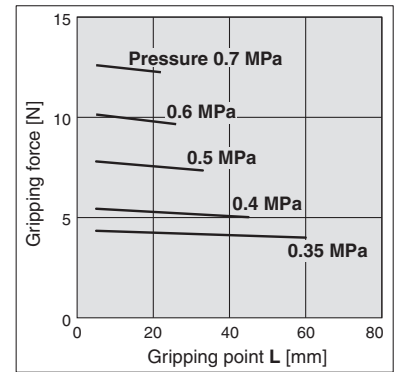

JMHZ2-12C

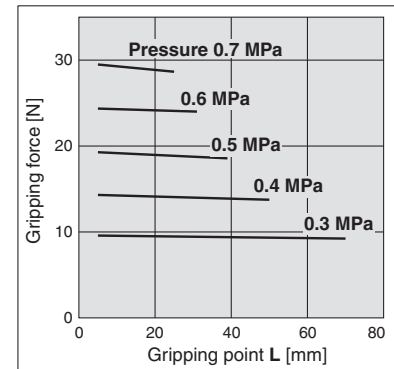

JMHZ2-16C

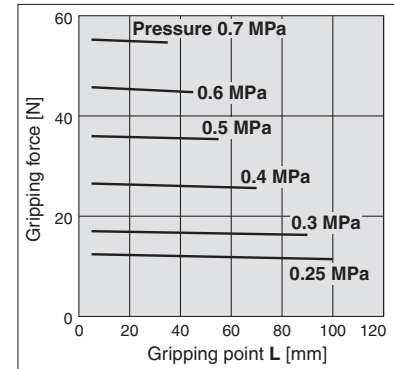

JMHZ2-20

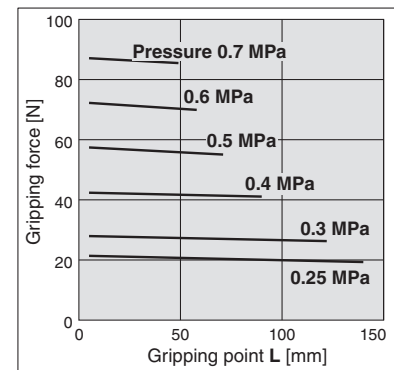

JMHZ2 Series

Model Selection

Step 2 Check the gripping point: JMHZ2 Series

External gripping state

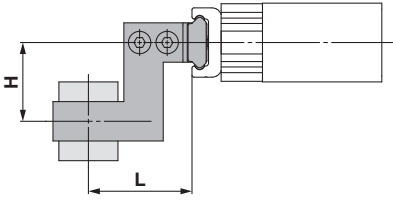

Internal gripping state

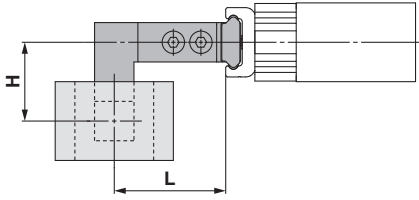

- The air gripper should be operated so that the workpiece gripping point "L" and the amount of overhang "H" stay within the range shown for each operating pressure given in the graphs to the right.
- If the workpiece gripping point goes beyond the range limits, this will have an adverse effect on the life of the air gripper.

External Grip

JMHZ2-8

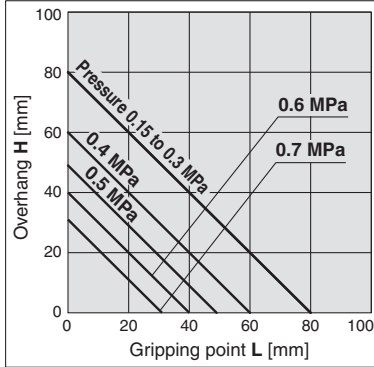

JMHZ2-12

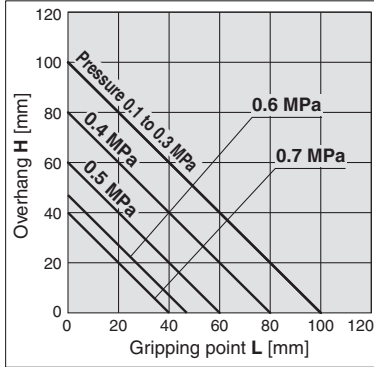

JMHZ2-16

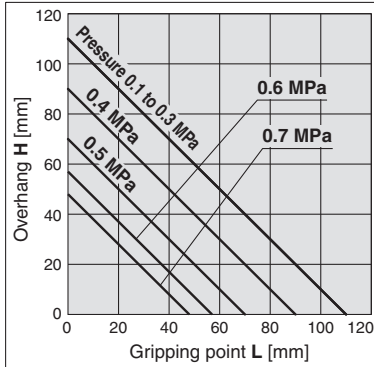

JMHZ2-20

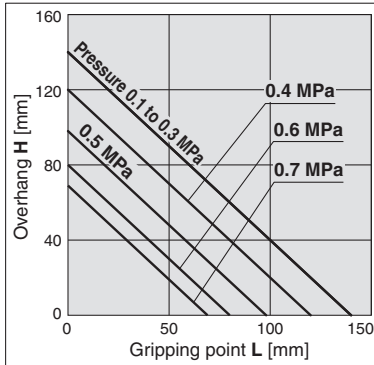

Internal Grip

JMHZ2-8

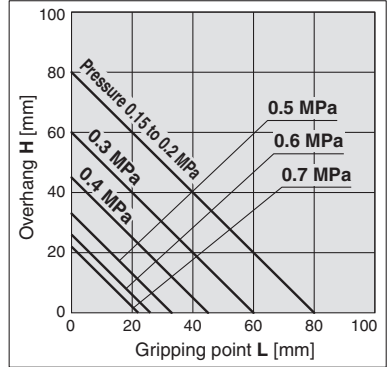

JMHZ2-12

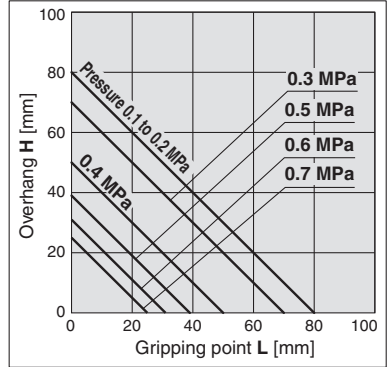

JMHZ2-16

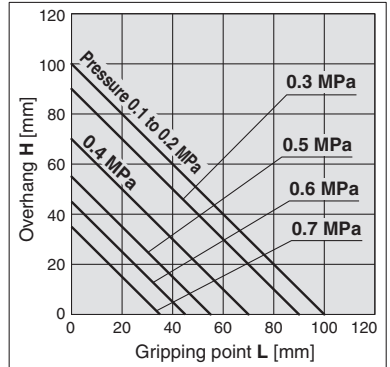

JMHZ2-20

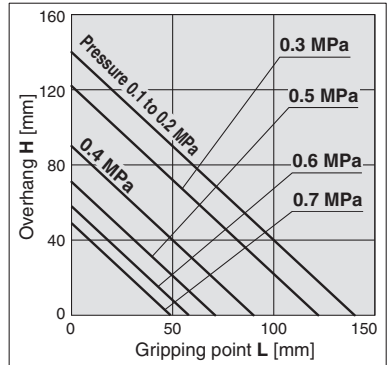

Step 3 Check the external force on fingers: JMHZ2 Series

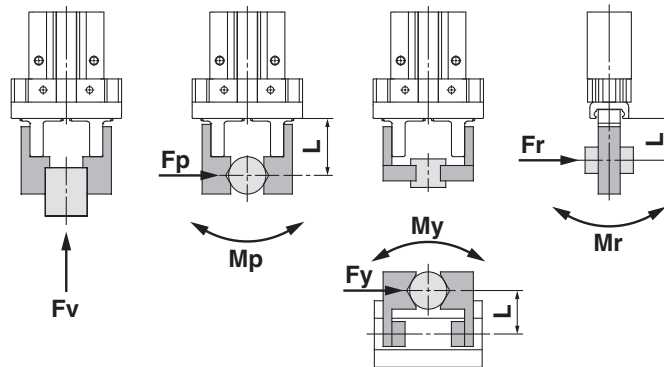

L: Distance to the point at which the load is applied [mm]

Model	Maximum allowable moment/load*1 *2				
	Vertical load Fvmax [N]	Pitch moment Mpmax [N·m]	Yaw moment Mymax [N·m]	Roll moment Mrmax [N·m]	Maximum lateral load Fp, Fy, Fr [N]*3
JMHZ2-8	58	0.26	0.26	0.52	14
JMHZ2-12	98	0.68	0.68	1.36	33
JMHZ2-16	147	1.32	1.32	2.64	62
JMHZ2-20	265	2.1	2.1	4.2	100

*1 Inertial loads will be generated at the stroke end when the product is used for transportation. Consider the rate of acceleration.

*2 Ensure moments and loads are the allowable values or less.

*3 Even when the dimension L is short, the maximum lateral load should not be exceeded.

When combining a vertical load and moment, make sure the load factor is 1 or less according to the equation below.

$Fv/Fvmax + Mp/Mpmax + My/Mymax + Mr/Mrmax \leq 1$ (Load factor)

Calculation Examples of External Force

1 Workpiece insertion

When a moment in one direction is applied

When a workpiece held by JMHZ2-16D at $L = 30$ mm, a roll moment Mr is generated due to load $Fr = 20$ [N].

$$Mr = Fr \times L \times 10^{-3*1} \quad (*1: \text{Constant for unit conversion})$$

$$= 20 \times 30 \times 10^{-3}$$

$$= 0.6 \text{ [N·m]}$$

The moment $Mr = 0.6$ [N·m] is the allowable moment of 1.32 [N·m] or less. The load $F = 20$ [N] is the allowable load of 62 [N] or less. The product is suitable for the workpiece.

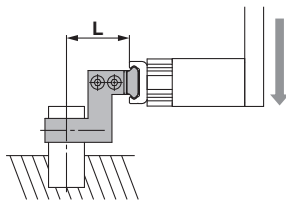

2 Workpiece transfer

When moments in multiple directions are applied

Hold the workpiece using JMHZ2-16D to transport it horizontally.

Attachment mass (One side) m_1 : 0.05 [kg]

Workpiece mass m_2 : 0.3 [kg]

Acceleration load A is generated when stopping at the end of transportation: $3g$ (g : Gravitational acceleration = 9.8 m/s²)

Calculate the followings: Load: Mass of the attachment and workpiece x acceleration (including their own weight). Moment: Mass x distance to the centre of gravity of the attachment and mass x distance to the centre of gravity of the workpiece.

1. Pitch direction (Moment due to acceleration speed)

$$Fp = (m_1 \times 2 + m_2) \times A$$

$$= (0.05 \times 2 + 0.3) \times 3 \times 9.8$$

$$= 11.76 \text{ [N]}$$

Distance to the centre of gravity of the attachment $La = 20$ mm,
Distance to the centre of gravity of the workpiece $Lb = 30$ mm

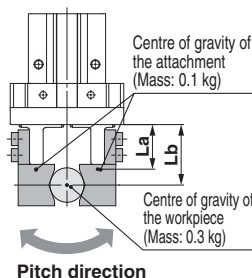

$$Mp = (m_1 \times La \times 10^{-3*1} \times 2 + m_2 \times Lb \times 10^{-3*1}) \times A$$

(*1: Constant for unit conversion)

$$= (0.05 \times 20 \times 10^{-3} \times 2 + 0.3 \times 30 \times 10^{-3}) \times 3 \times 9.8$$

$$\approx 0.32 \text{ [N·m]}$$

2. Yaw direction (Moment due to acceleration speed)

Distance to the centre of gravity of the attachment $La = 15$ mm,
Distance to the centre of gravity of the workpiece $Lb = 18$ mm

$$Fy = (m_1 \times 2 + m_2) \times A$$

$$= (0.05 \times 2 + 0.3) \times 3 \times 9.8$$

$$= 11.76 \text{ [N]}$$

$$My = (m_1 \times La \times 10^{-3*1} \times 2 + m_2 \times Lb \times 10^{-3*1}) \times A$$

$$= (0.05 \times 15 \times 10^{-3} \times 2 + 0.3 \times 18 \times 10^{-3}) \times 3 \times 9.8$$

$$\approx 0.20 \text{ [N·m]}$$

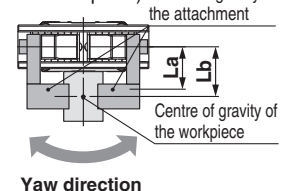

3. Roll direction (Moment due to the own weight of the attachment and workpiece)

Distance to the centre of gravity of the attachment $La = 20$ mm,
Distance to the centre of gravity of the workpiece $Lb = 30$ mm

$$Fr = (m_1 \times 2 + m_2) \times g$$

$$= (0.05 \times 2 + 0.3) \times 9.8$$

$$= 3.92 \text{ [N]}$$

$$Mr = (m_1 \times La \times 10^{-3*1} \times 2 + m_2 \times Lb \times 10^{-3*1}) \times g$$

$$= (0.05 \times 20 \times 10^{-3} \times 2 + 0.3 \times 30 \times 10^{-3}) \times 9.8$$

$$\approx 0.11 \text{ [N·m]}$$

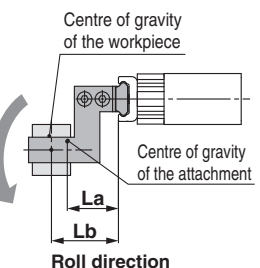

Moments: $Mp + My + Mr = 0.32 + 0.20 + 0.11 = 0.63$ [N·m] is the allowable moment of 1.32 [N·m] or less. Loads: Fp , Fy and Fr of each direction is the maximum allowable load of 62 [N] or less. The product is suitable for the workpiece.

Compact Type Parallel Style Air Gripper

JMHZ2 Series

∅ 8, ∅ 12, ∅ 16, ∅ 20

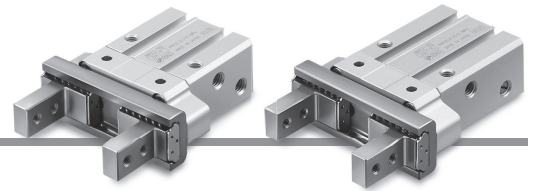

How to Order

Bore Size

∅ 8 to ∅ 20 **JMHZ2-16D** **-M9BW** **-**

Number of fingers

2	2
---	---

Bore size

8	8 mm
12	12 mm
16	16 mm
20	20 mm

Action

D	Double acting
S	Single acting (Normally open)
C	Single acting (Normally closed)

Number of auto switches

—	2
S	1
n	n

Auto switch

—	Without auto switch (Built-in magnet)
---	---------------------------------------

Made-to-order individual specifications
For details, refer to page 10.

* For applicable auto switches, refer to the table below.

Finger option

[Standard]
—: Basic

1: Side tapped mounting

2: Through-holes in opening/closing direction

Moisture Control Tube IDK Series

When operating an actuator with a small bore size and a short stroke at a high frequency, dew condensation (water droplets) may occur inside the piping depending on the conditions. Simply connecting the moisture control tube to the actuator will prevent dew condensation from occurring. For details, refer to the **Catalogue at www.smc.eu** and the Best Pneumatics Catalogue.

Applicable Auto Switches/Refer to the Catalogue at www.smc.eu and the Best Pneumatics Catalogue for further information on auto switches.

Type	Special function	Electrical entry	Indicator/light	Wiring (Output)	Load voltage		Auto switch model		Lead wire length [m] ^{*1}				Pre-wired connector	Applicable load		
					DC	AC	Perpendicular	In-line	0.5 (—)	1 (M)	3 (L)	5 (Z)				
Solid state auto switch	—	Grommet	Yes	3-wire (NPN)	5 V, 12 V	—	M9NV	M9N	●	●	●	○	○	IC circuit		
				3-wire (PNP)			M9PV	M9P	●	●	●	○				
				2-wire	M9BV		M9B	●	●	●	○	—				
				3-wire (NPN)	M9NWV		M9NW	●	●	●	○	IC circuit				
				3-wire (PNP)	M9PWV		M9PW	●	●	●	○	IC circuit				
				2-wire	M9BWV		M9BW	●	●	●	○	—				
	Diagnostic indication (2-colour indicator)			24 V	3-wire (NPN)		5 V, 12 V	M9NAV ^{*2}	M9NA ^{*2}	○	○	●	○	○	○	IC circuit
					3-wire (PNP)			M9PAV ^{*2}	M9PA ^{*2}	○	○	●	○	○		
					2-wire		M9BAV ^{*2}	M9BA ^{*2}	○	○	●	○	○	—		
					2-wire				○	○	●	○	○	—		

*1 Lead wire length symbols: 0.5 m..... —
1 m..... M
3 m..... L
5 m..... Z

*2 Water-resistant type auto switches can be mounted on the above models, but SMC cannot guarantee water resistance.

* Auto switches marked with "○" are produced upon receipt of order.

* When using the 2-colour indicator type, please make the setting so that the indicator is lit in red to ensure the detection at the proper position of the air gripper.

* An auto switch with a reduced overall length for the D-M9□ is available upon request. (Produced upon receipt of order)
Please contact your local sales representative for more details.

Compact Type Parallel Style Air Gripper **JMHZ2 Series**

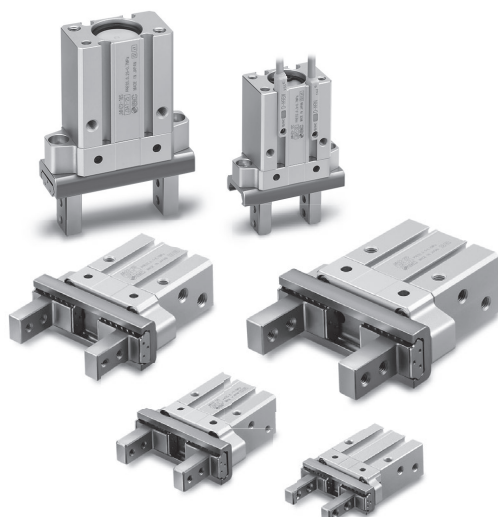

Specifications

Bore size [mm]		8	12	16	20
Fluid		Air			
Operating pressure	Double acting	Ø 8: 0.15 to 0.7 MPa Ø 12 to Ø 20: 0.1 to 0.7 MPa			
	Single acting	Normally open	Ø 8: 0.35 to 0.7 MPa Ø 12: 0.3 to 0.7 MPa		
Normally closed		Ø 16 to Ø 20: 0.25 to 0.7 MPa			
Ambient and fluid temperatures		-10 to 60°C (No freezing)			
Repeatability		±0.01 mm			
Max. operating frequency		120 c.p.m.			
Lubricant		Non-lube			
Action		Double acting, Single acting			
Auto switch (Option)*1		Solid state auto switch (3-wire, 2-wire)			

*1 Refer to pages 16 to 18 for details on auto switches.

Symbol

Double acting, Internal grip

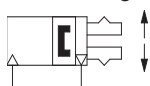

Double acting, External grip

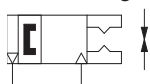

Single acting (Normally closed), Internal grip

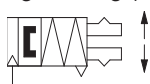

Single acting (Normally open), Internal grip



Model

Action	Model	Bore size [mm]	Gripping force*1		Opening/Closing stroke (Both sides) [mm]	Weight*2 [g]	Volume [cm³]		
			Effective gripping force per finger [N]	External			Internal	Finger opening port	Finger closing port
Double acting	JMHZ2-8D	8	7.8	10.5	4	32	0.3	0.2	
	JMHZ2-12D	12	17.5	23.3	6	61	0.6	0.4	
	JMHZ2-16D	16	32.7	43.5	10	119	1.6	1.1	
	JMHZ2-20D	20	54.2	72.2	14	244	3.3	2.2	
Single acting	Normally open	JMHZ2-8S	8	4.5	—	4	35	0.3	0.2
		JMHZ2-12S	12	11.2	—	6	72	0.8	0.6
		JMHZ2-16S	16	22.9	—	10	142	2.2	1.5
		JMHZ2-20S	20	38.3	—	14	270	4.5	3.1
	Normally closed	JMHZ2-8C	8	—	7.8	4	35	0.3	0.2
		JMHZ2-12C	12	—	19.3	6	72	0.8	0.5
		JMHZ2-16C	16	—	36.0	10	142	2.4	1.3
		JMHZ2-20C	20	—	57.4	14	270	4.7	2.6

*1 At a pressure of 0.5 MPa, gripping point L = 20 mm, centre of stroke

*2 Excluding the auto switch weight



Made-to-Order Individual Specifications
(For details, refer to pages 20 and 21.)

Symbol	Specifications
-X6900□	With positioning pins on the lateral mounting surface
-X7460	Lateral auto switch mounting

Refer to pages 16 to 18 for grippers with auto switches.

- Auto Switch Installation Examples and Mounting Positions
- Auto Switch Hysteresis
- Auto Switch Mounting
- Protrusion of Auto Switch from Edge of Body

⚠ Precautions

Be sure to read this before handling the products. Refer to page 22 for details.

JMHZ2 Series

Construction: JMHZ2-8□ to 20□

Double acting, With fingers open

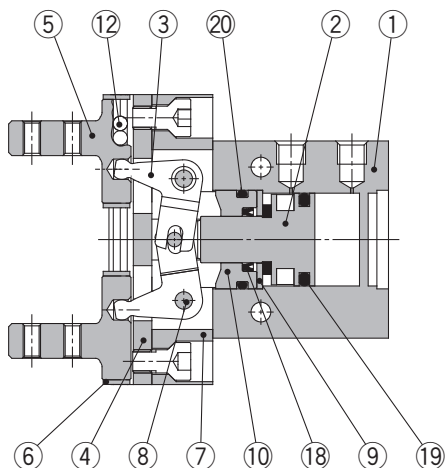

Single acting, Normally open

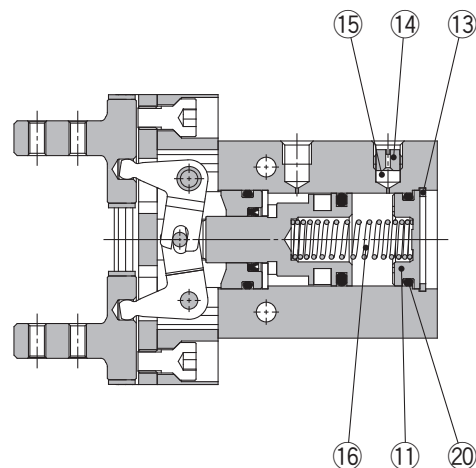

Double acting, With fingers closed

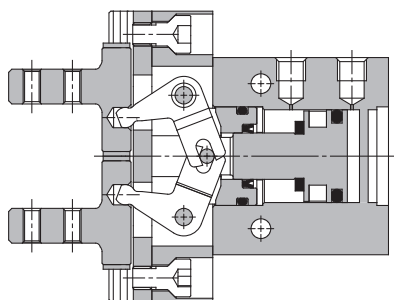

Single acting, Normally closed

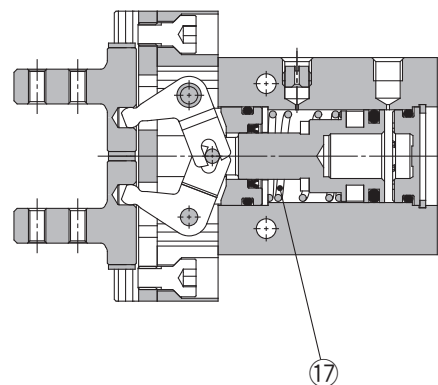

Component Parts

No.	Description
1	Body A
2	Piston assembly
3	Lever
4	Guide
5	Finger
6	Roller stopper
7	Body B
8	Lever shaft
9	Seal support
10	Rod cover

No.	Description
11	Cap
12	Steel ball
13	Type C retaining ring for hole
14	Exhaust plug A
15	Exhaust filter A
16	N.O. spring
17	N.C. spring
18	Rod seal
19	Piston seal
20	Gasket

Replacement Parts

Description		JMHZ2-8	JMHZ2-12	JMHZ2-16	JMHZ2-20	Contents
Seal kit	JMHZ2-□□D	JMHZ8-PS	JMHZ12-PS	JMHZ16-PS	JMHZ20-PS	⑱⑲⑳
	JMHZ2-□□S	JMHZ8S-PS	JMHZ12S-PS	JMHZ16S-PS	JMHZ20S-PS	
	JMHZ2-□□C					
Finger assembly	JMHZ2-□□□□	JMHZ-A0802	JMHZ-A1202	JMHZ-A1602	JMHZ-A1602	④⑤⑥⑫ Mounting screw
	JMHZ2-□□□□1	JMHZ-A0802-1	JMHZ-A1202-1	JMHZ-A1602-1	JMHZ-A1602-1	
	JMHZ2-□□□□2	JMHZ-A0802-2	JMHZ-A1202-2	JMHZ-A1602-2	JMHZ-A1602-2	
Piston assembly	JMHZ2-□□D	JMHZ-A0803	JMHZ-A1203	JMHZ-A1603	JMHZ-A2003	②
	JMHZ2-□□S	JMHZ-A0803S	JMHZ-A1203S	JMHZ-A1603S	JMHZ-A2003S	
	JMHZ2-□□C	JMHZ-A0803C				
Lever assembly		JMHZ-A0804	JMHZ-A1204	JMHZ-A1604	JMHZ-A2004	③

* Finger option

1 = Side tapped, 2 = Through-hole

* The seal kit does not include a grease pack. Order it separately. Grease pack part number: GR-S-010 (10 g)

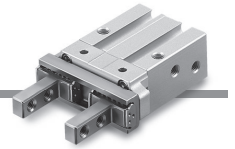

Dimensions

Basic type: JMHZ2-8□

The values inside () are dimensions for the single acting type.

Dimensions of auto switch mounting groove

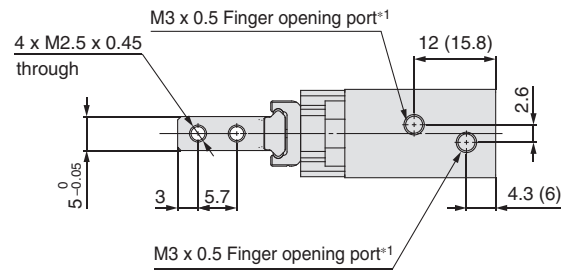
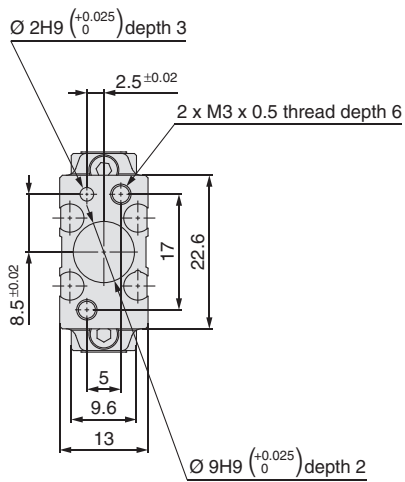
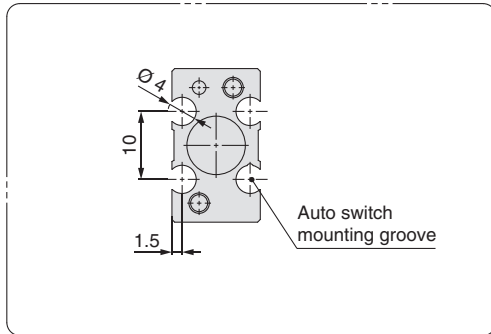

*1 For single action, the port on one side is a breathing hole.

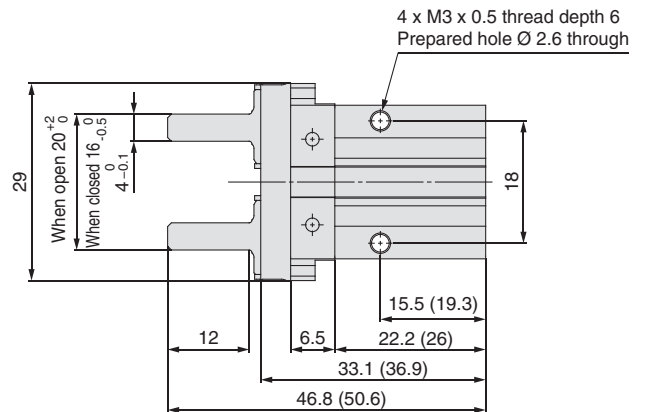

Side tapped mounting JMHZ2-8□1

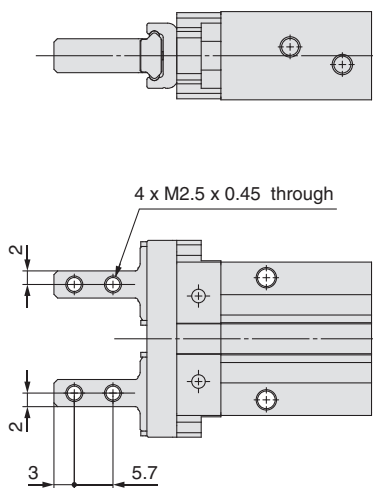

Through-holes in opening/closing direction JMHZ2-8□2

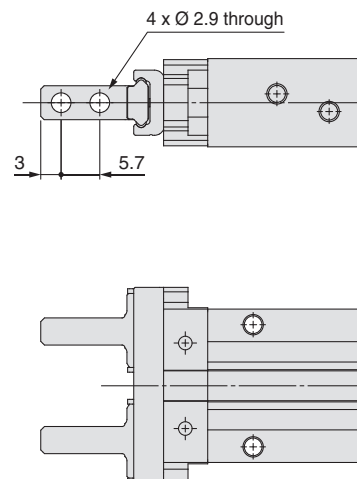

JMHZ2 Series

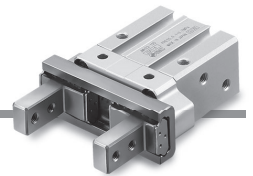

Dimensions

Basic type: JMHZ2-12□

The values inside () are dimensions for the single acting type.

Dimensions of auto switch mounting groove

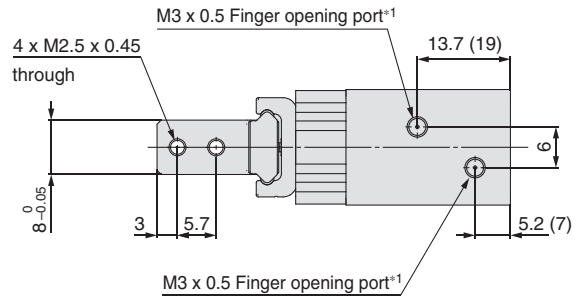
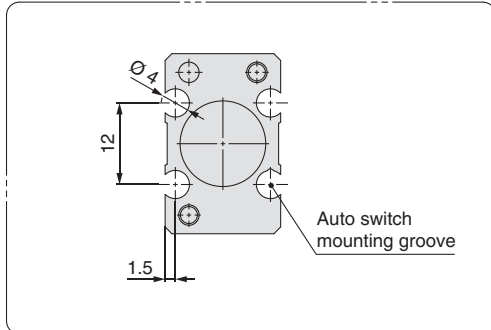

*1 For single action, the port on one side is a breathing hole.

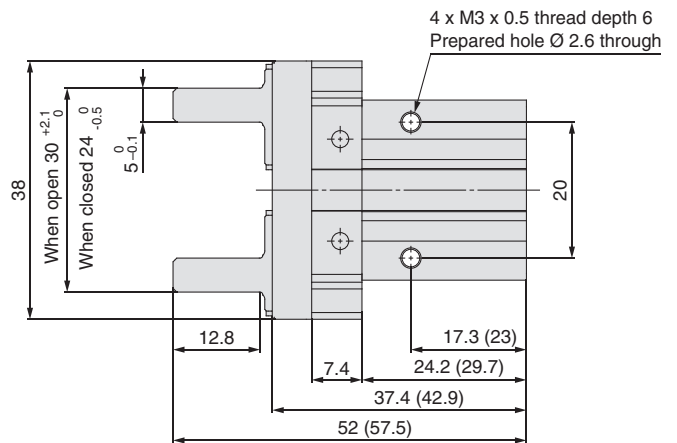
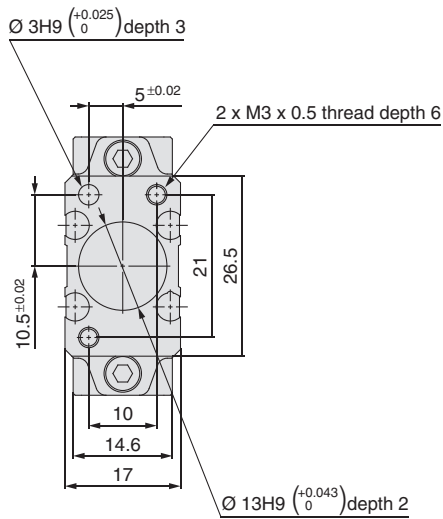

Side tapped mounting JMHZ2-12□1

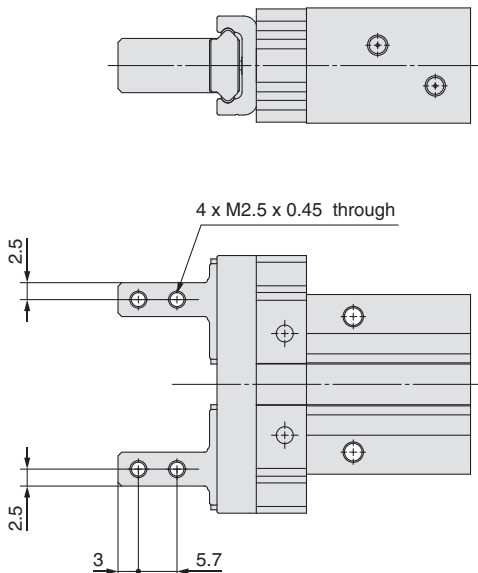

Through-holes in opening/closing direction JMHZ2-12□2

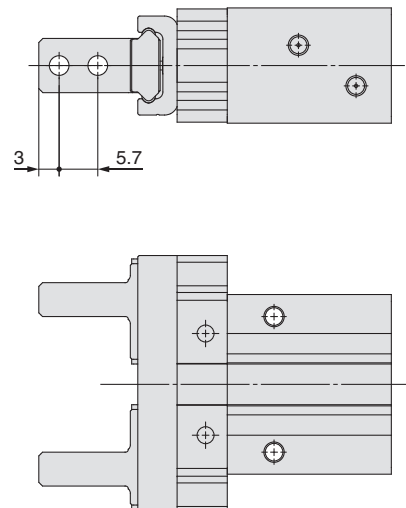

*1 Other dimensions are the same as the basic type.

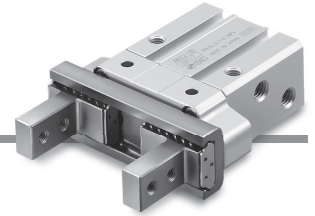

Dimensions

Basic type: JMHZ2-16□

The values inside () are dimensions for the single acting type.

Dimensions of auto switch mounting groove

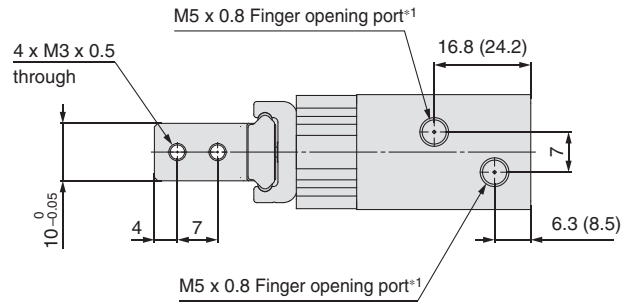
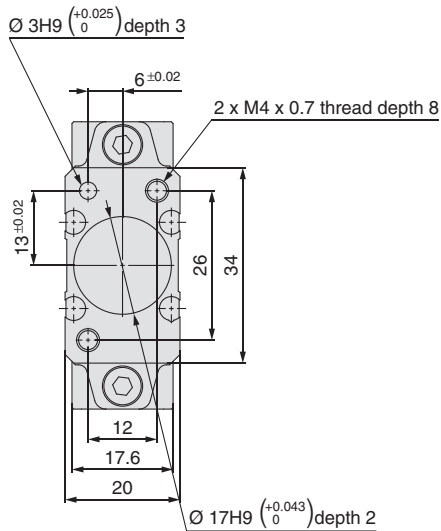
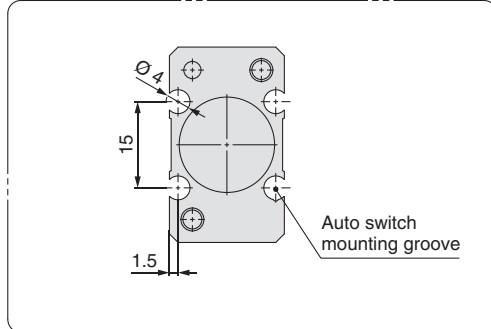

*1 For single action, the port on one side is a breathing hole.

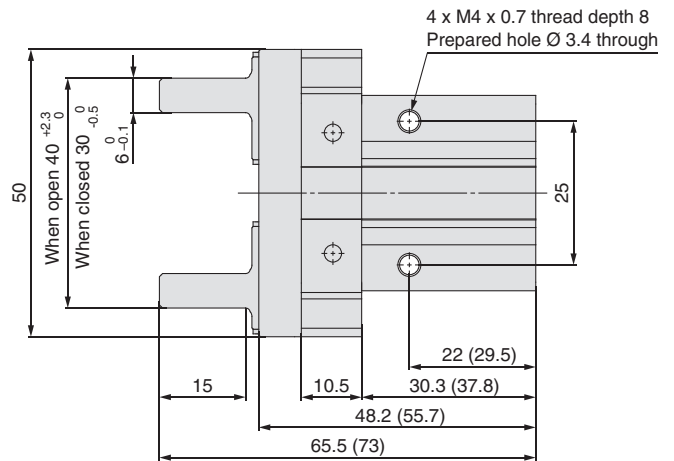

Side tapped mounting JMHZ2-16□1

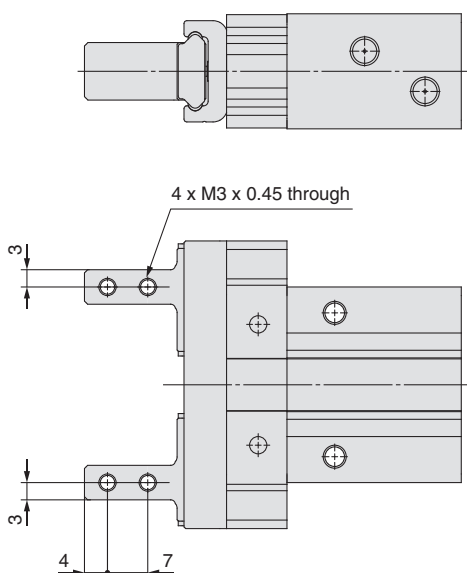

Through-holes in opening/closing direction JMHZ2-16□2

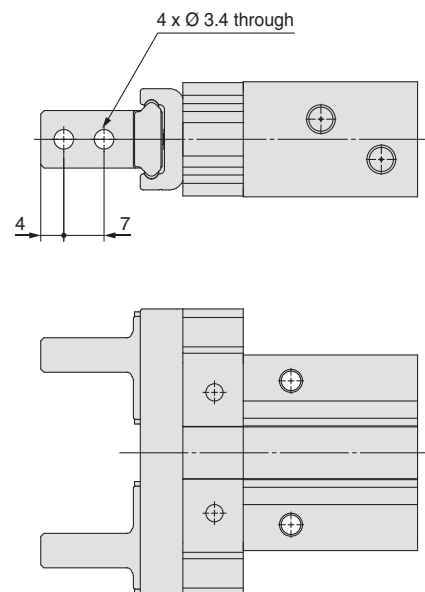

JMHZ2 Series

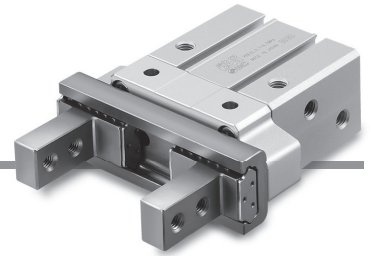

Dimensions

Basic type: JMHZ2-20□

The values inside () are dimensions for the single acting type.

Dimensions of auto switch mounting groove

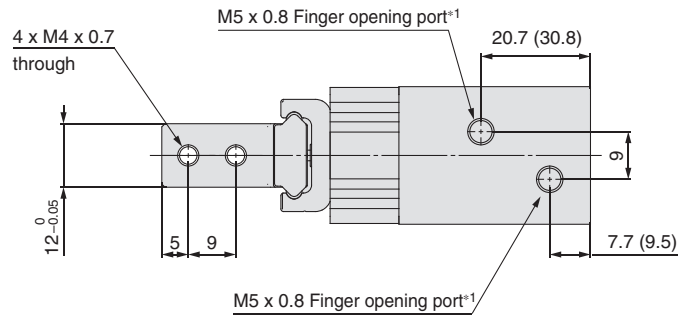
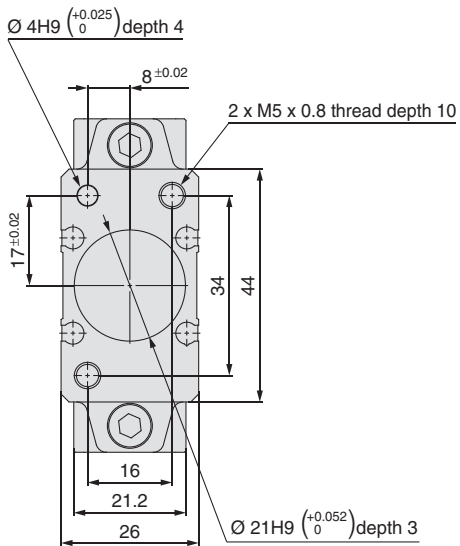
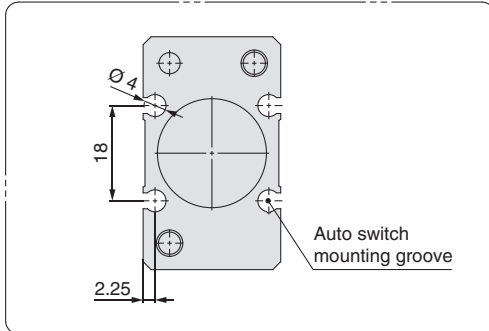

*1 For single action, the port on one side is a breathing hole.

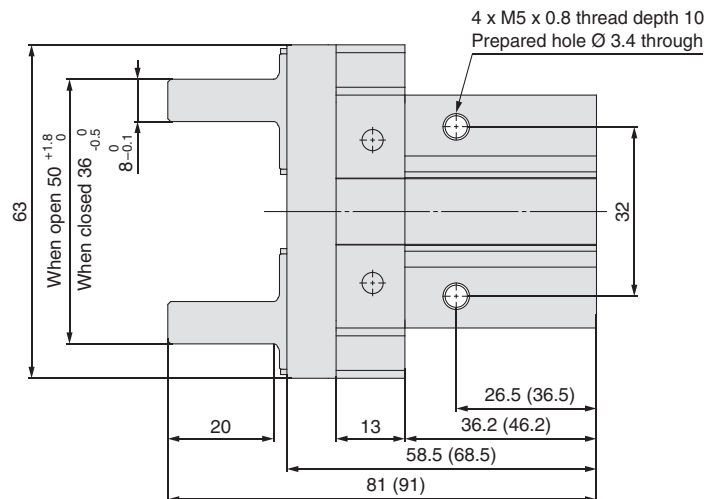

Side tapped mounting JMHZ2-20□1

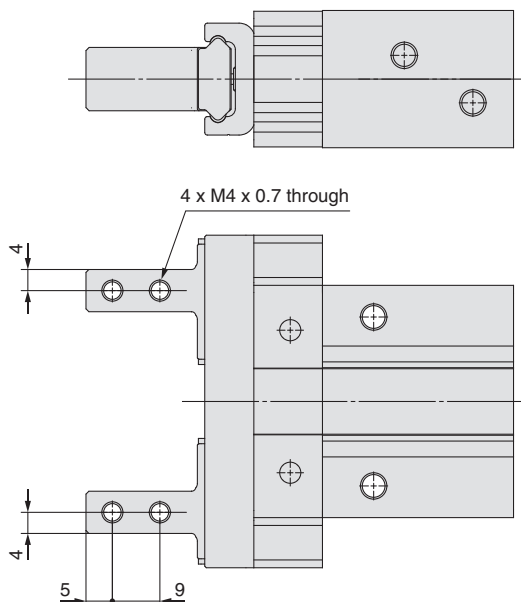

Through-holes in opening/closing direction JMHZ2-20□2

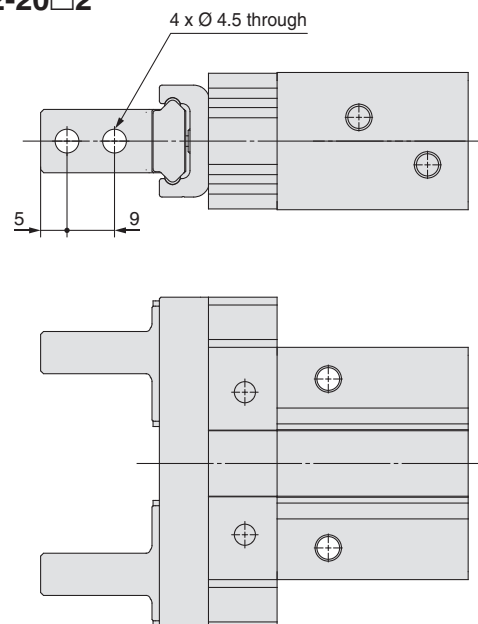

*1 Other dimensions are the same as the basic type.

JMHZ2 Series

Auto Switch Installation Examples and Mounting Positions

Various auto switch applications are possible through different combinations of auto switch quantities and detecting positions.

1) Detection when Gripping Exterior of a Workpiece

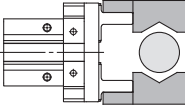
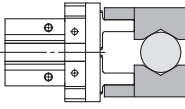
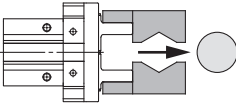
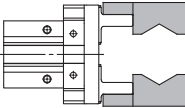
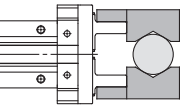
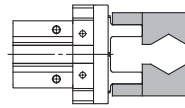
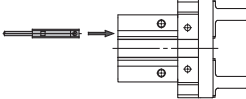
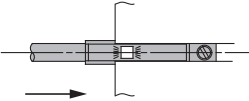
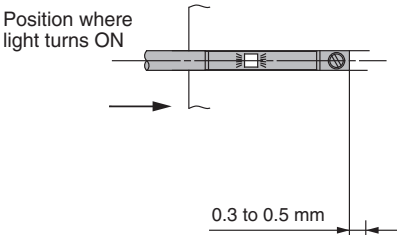
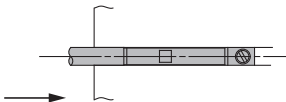
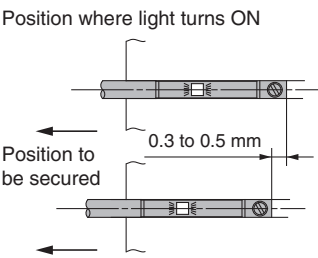
Detection example		① Confirmation of fingers in reset position	② Confirmation of a workpiece held	③ Confirmation of a workpiece released	
Position to be detected		Position of fingers fully open 	Position when gripping a workpiece 	Position of fingers fully closed 	
Operation of auto switches		When fingers return: Auto switch to turn ON (Light ON)	When gripping a workpiece: Auto switch to turn ON (Light ON)	When a workpiece is not held (Abnormal operation): Auto switch to turn ON (Light ON)	
Detection combinations	One auto switch * One position, any of ①, ② and ③ can be detected.	●	●	●	
	Two auto switches * Two positions of ①, ② and ③ can be detected.	Pattern A	●	—	
		Pattern B	—	●	●
Pattern C	●	—	●		
How to determine auto switch installation position		Step 1) Fully open the fingers. 	Step 1) Position fingers for gripping a workpiece. 	Step 1) Fully close the fingers. 	
At no pressure or low pressure, connect the auto switch to a power supply, and follow the directions.		Step 2) Insert the auto switch into the auto switch mounting groove in the direction as shown in the illustration below. 			
		Step 3) Slide the auto switch in the direction of the arrow until the indicator light illuminates. 	Step 3) Slide the auto switch in the direction of the arrow until the indicator light illuminates and fasten it at a position 0.3 to 0.5 mm in the direction of the arrow beyond the position where the indicator light illuminates. 		
		Step 4) Slide the auto switch further in the direction of the arrow until the indicator light goes out. 	Step 5) Slide the auto switch in the opposite direction and fasten it at a position 0.3 to 0.5 mm beyond the position where the indicator light illuminates. 		



* It is recommended that gripping of a workpiece be performed close to the centre of the finger stroke.

• When holding a workpiece close at the end of opening/closing stroke of fingers, detecting performance of the combinations listed in the table above may be limited, depending on the hysteresis of an auto switch, etc.

JMHZ2 Series

Various auto switch applications are possible through different combinations of auto switch quantities and detecting positions.

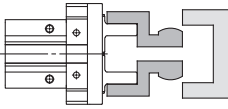
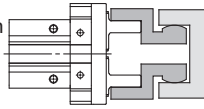
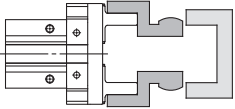
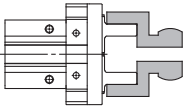
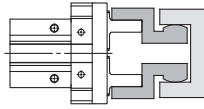
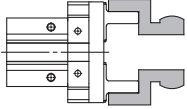
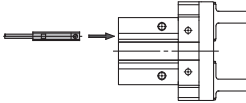
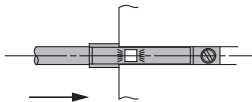
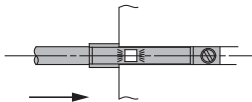
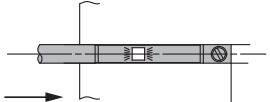
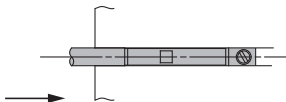
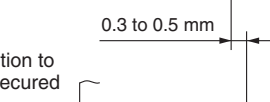
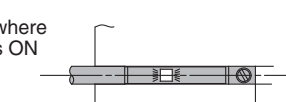
2) Detection when Gripping Interior of a Workpiece

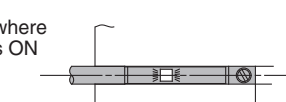
Detection example		① Confirmation of fingers in reset position	② Confirmation of a workpiece held	③ Confirmation of a workpiece released	
Position to be detected		Position of fingers fully closed 	Position when gripping a workpiece 	Position of fingers fully open 	
Operation of auto switches		When fingers return: Auto switch to turn ON (Light ON)	When gripping a workpiece: Auto switch to turn ON (Light ON)	When a workpiece is not held (Abnormal operation): Auto switch to turn ON (Light ON)	
Detection combinations	One auto switch * One position, any of ①, ② and ③ can be detected.	●	●	●	
	Two auto switches * Two positions of ①, ② and ③ can be detected.	Pattern A	●	—	
		Pattern B	—	●	●
Pattern C	●	—	●		
How to determine auto switch installation position		Step 1) Fully close the fingers. 	Step 1) Position fingers for gripping a workpiece. 	Step 1) Fully open the fingers. 	
At no pressure or low pressure, connect the auto switch to a power supply, and follow the directions.		Step 2) Insert the auto switch into the auto switch mounting groove in the direction as shown in the illustration below. 			
		Step 3) Slide the auto switch in the direction of the arrow until the indicator light illuminates and fasten it at a position 0.3 to 0.5 mm in the direction of the arrow beyond the position where the indicator light illuminates. 	Step 3) Slide the auto switch in the direction of the arrow until the indicator light illuminates. 		
		 Position where light turns ON	Step 4) Slide the auto switch further in the direction of the arrow until the indicator light goes out. 		
		 Position to be secured 0.3 to 0.5 mm	Step 5) Slide the auto switch in the opposite direction and fasten it at a position 0.3 to 0.5 mm beyond the position where the indicator light illuminates. 		
		 Position to be secured 0.3 to 0.5 mm	 Position where light turns ON 0.3 to 0.5 mm Position to be secured		

* It is recommended that gripping of a workpiece be performed close to the centre of the finger stroke.

• When holding a workpiece close at the end of opening/closing stroke of fingers, detecting performance of the combinations listed in the table above may be limited, depending on the hysteresis of an auto switch, etc.

Auto Switch Hysteresis

Auto switches have hysteresis similar to micro switches. Use the table below as a guide when adjusting auto switch positions, etc.

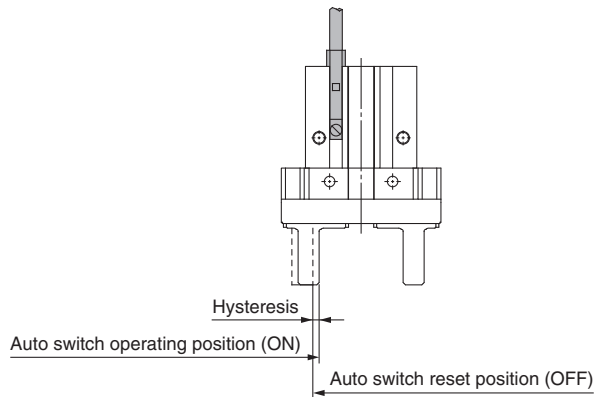

Hysteresis

Auto switch model	D-M9□(V) D-M9□W(V) D-M9□A(V)
JMHZ2-8	0.7
JMHZ2-12	0.6
JMHZ2-16	0.7
JMHZ2-20	0.6

Auto Switch Mounting

To set the auto switch, insert the auto switch into the auto switch installation groove of the gripper from the direction as shown in the illustration below. After setting the position, tighten the attached auto switch mounting screw with a flat blade watchmaker's screwdriver.

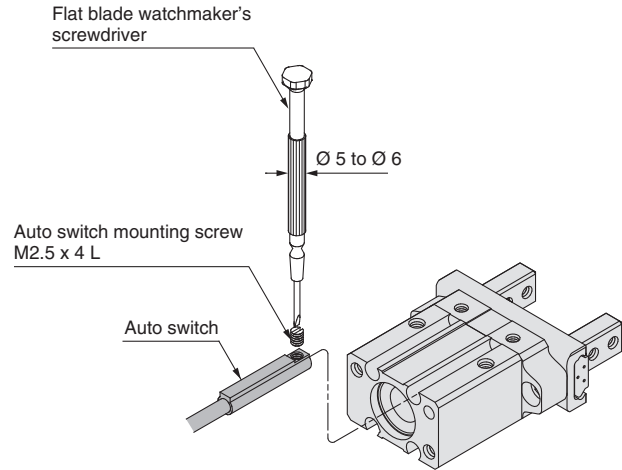

* Use a watchmaker's screwdriver with a grip diameter of 5 to 6 mm to tighten the auto switch mounting screw. Also, tighten with a torque of about 0.05 to 0.15 N·m, or about 0.05 to 0.10 N·m for D-M9□A(V).

Protrusion of Auto Switch from Edge of Body

The amount of auto switch protrusion from the body end surface is shown in the table below. Use this as a standard when mounting, etc.

Protrusion of Auto Switch

[mm]

Lead wire type		Illustration	In-line entry		Perpendicular entry	
			D-M9□ D-M9□W	D-M9□A	D-M9□V D-M9□WV	D-M9□AV
Double acting	JMHZ2-8D	Open	5	7	3	5
		Closed	7.5	9.5	5.5	7.5
	JMHZ2-12D	Open	3.5	5.5	1.5	3.5
		Closed	7.5	9.5	5.5	7.5
	JMHZ2-16D	Open	—	2.0	—	—
		Closed	5.5	7.5	3.5	5.5
	JMHZ2-20D	Open	—	—	—	—
		Closed	4	6	2	4
Single acting (Normally open)	JMHZ2-8S	Open	1	3	—	1
		Closed	4	6	2	4
	JMHZ2-12S	Open	2	4	—	2
		Closed	6	8	4	6
	JMHZ2-16S	Open	—	—	—	—
		Closed	4	6	2	4
	JMHZ2-20S	Open	—	—	—	—
		Closed	2	4	—	2
Single acting (Normally closed)	JMHZ2-8C	Open	4	6	2	4
		Closed	6	8	4	6
	JMHZ2-12C	Open	2	4	—	2
		Closed	6	8	4	6
	JMHZ2-16C	Open	—	—	—	—
		Closed	4	6	2	4
	JMHZ2-20C	Open	—	—	—	—
		Closed	2	4	—	2

* There is no protrusion for sections of the table with no values entered.

Prior to Use

Auto Switch Connections and Examples

Sink Input Specifications

3-wire, NPN

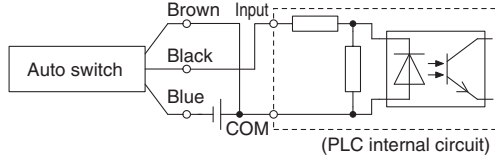

2-wire

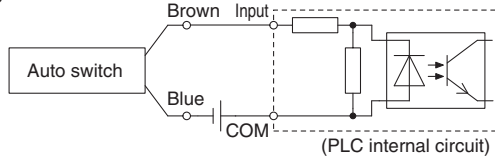

Source Input Specifications

3-wire, PNP

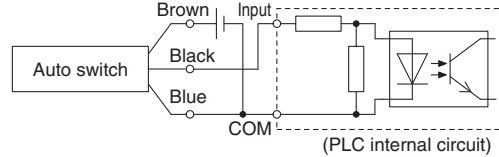

2-wire

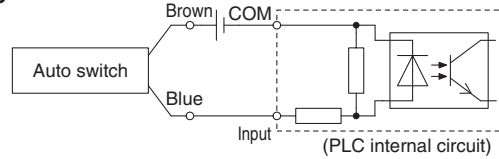

Connect according to the applicable PLC input specifications, as the connection method will vary depending on the PLC input specifications.

Examples of AND (Series) and OR (Parallel) Connections

* When using solid state auto switches, ensure the application is set up so the signals for the first 50 ms are invalid. Depending on the operating environment, the product may not operate properly.

3-wire AND connection for NPN output (Using relays)

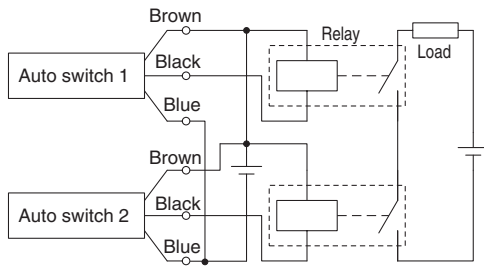

(Performed with auto switches only)

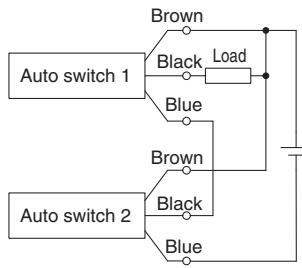

3-wire OR connection for NPN output

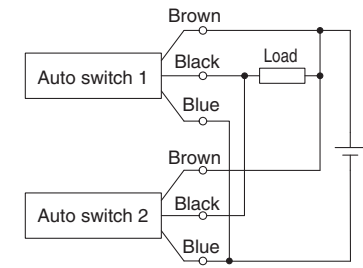

3-wire AND connection for PNP output (Using relays)

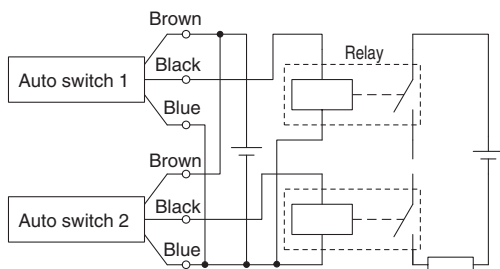

(Performed with auto switches only)

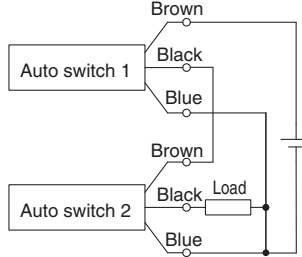

3-wire OR connection for PNP output

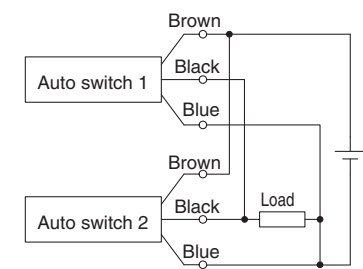

2-wire AND connection

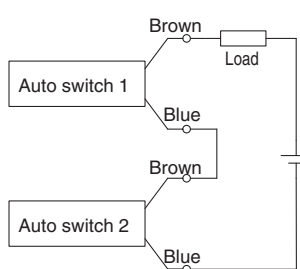

When two auto switches are connected in series, a load may malfunction because the load voltage will decline when in the ON state. The indicator lights will light up when both of the auto switches are in the ON state. Auto switches with a load voltage less than 20 V cannot be used. Please contact SMC if using AND connection for a heat-resistant solid state auto switch or a trimmer switch.

Example) Load voltage at ON
 Power supply voltage: 24 VDC
 Internal voltage drop: 4 V
 Load voltage at ON = Power supply voltage –
 Internal voltage drop x 2 pcs.
 = 24 V – 4 V x 2 pcs.
 = 16 V

2-wire OR connection

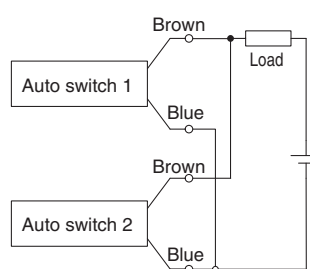

(Solid state)
 When two auto switches are connected in parallel, malfunction may occur because the load voltage will increase when in the OFF state.

(Reed)
 Because there is no current leakage, the load voltage will not increase when turned OFF. However, depending on the number of auto switches in the ON state, the indicator lights may sometimes grow dim or not light up, due to the dispersion and reduction of the current flowing to the auto switches.

Example) Load voltage at OFF
 Leakage current: 1 mA
 Load impedance: 3 kΩ
 Load voltage at OFF = Leakage current x 2 pcs. x
 Load impedance
 = 1 mA x 2 pcs. x 3 kΩ
 = 6 V

JMHZ2 Series

Made-to-Order Individual Specifications



1 With Positioning Pins on the Lateral Mounting Surface

Symbol
-X6900

The lever shaft can be extended and used as a positioning pin for lateral mounting.

How to Order

JMHZ2 - **8** **D** - X6900 **A**

Bore size	
8	8 mm
12	12 mm
16	16 mm
20	20 mm

Action	
D	Double acting
S	Single acting (Normally open)
C	Single acting (Normally closed)

Finger option	
—	Standard
1	Side tapped mounting
2	Through-holes in opening/closing direction

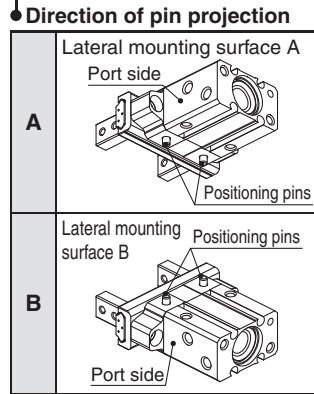

Specifications

Bore size [mm]	8, 12, 16, 20
Pin mounting surface	Lateral mounting surface
Pin diameter	Refer to the dimensions.
Mounting position	Refer to the dimensions.
Other specifications	The same as those of the standard type

With positioning pins on the lateral mounting surface

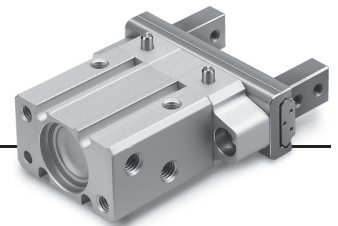

Dimensions

JMHZ2-□-X6900A

JMHZ2-□-X6900B

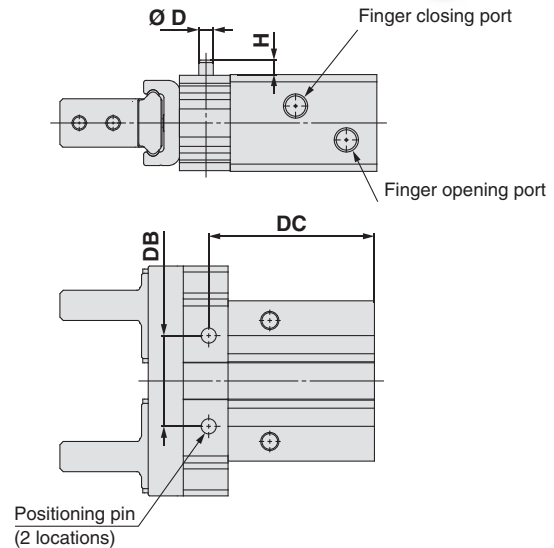
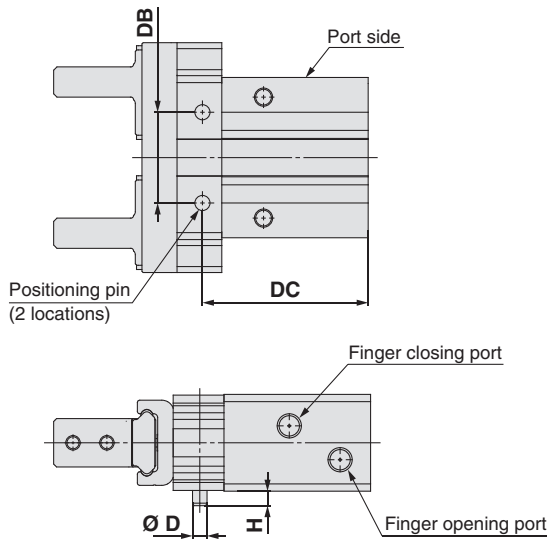

Model	Ø D	H	DB	DC
JMHZ2-8	Ø 2h8 ($0_{-0.014}^0$)	2.5	12.6 ±0.06	25.5 (29.3)
JMHZ2-12	Ø 2.5h8 ($0_{-0.014}^0$)	2.5	15 ±0.06	27.4 (32.9)
JMHZ2-16	Ø 3h8 ($0_{-0.014}^0$)	3	21 ±0.06	35.3 (42.8)
JMHZ2-20	Ø 4h8 ($0_{-0.018}^0$)	4	27 ±0.06	42.3 (52.3)

* The values inside () are dimensions for the single acting type.

2 Lateral Auto Switch Mounting

Symbol
-X7460

The auto switch can be replaced even when the head side is blocked.

How to Order

JMHZ2 - **8** D **□** - X7460

Bore size		Lateral auto switch mounting	
8	8 mm	—	Standard
12	12 mm	1	Side tapped mounting
16	16 mm	2	Through-holes in opening/closing direction
20	20 mm		
Action			
D	Double acting		

Specifications

Mounting	Plate mounting (Exclusive body)
Mounting position	Lateral mounting surface (2 surfaces)
Other specifications	The same as those of the standard type

Dimensions

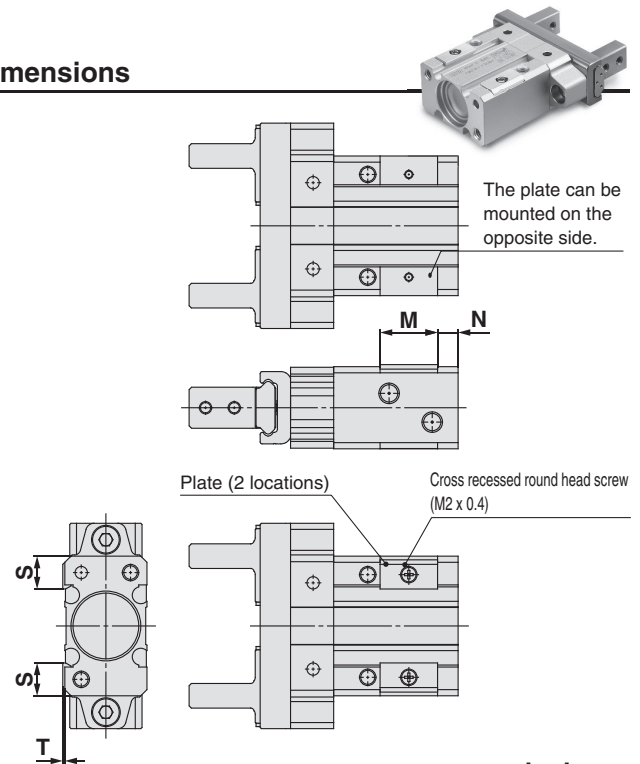

Model	N	M	S	T
JMHZ2-8	1.2	12	4.8	0.5
JMHZ2-12	3	12	5.75	0.5
JMHZ2-16	5	14	8	0.5
JMHZ2-20	8	14	11.5	—

Auto Switch Replacement

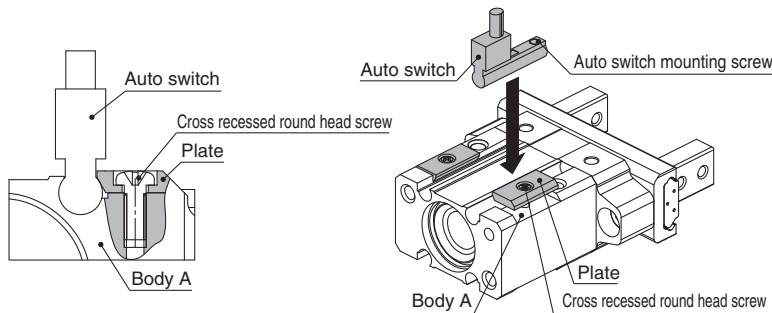

Auto Switch Replacement

- Loosen the cross recessed round head screw to create a gap between the plate and body A, and then replace the auto switch.
- When tightening the cross recessed round head screw, be careful not to press the auto switch housing with the plate. (To secure the auto switch, tighten the auto switch mounting screw.)
- The tightening torque for cross recessed round head screws should be approximately 0.09 to 0.15 N·m.

Mounting Precautions

⚠ Caution

1. For bore sizes 8 to 16, the auto switch interferes with the bolt for through-hole mounting, so it cannot be replaced from the plate side.

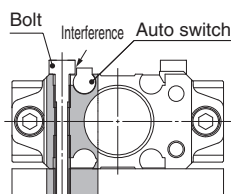

2. There are counterbores for bore sizes 8 and 12. Select the bolt length so that the screw-in depth L will be 5 to 6 mm.

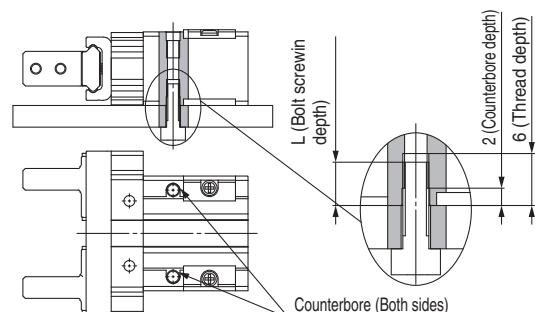



JMHZ2 Series Specific Product Precautions

Be sure to read this before handling the products. Refer to the back cover for safety instructions. For air gripper and auto switch precautions, refer to the "Handling Precautions for SMC Products" and the "Operation Manual" on the SMC website: <https://www.smcworld.com>

Operating Environment

⚠ Caution

Use caution for the anti-corrosiveness of the linear guide unit. Martensitic stainless steel is used for the finger guide. However, the anti-corrosiveness of this steel is inferior to that of austenitic stainless steel. In particular, rust may be generated in environments where waterdrops are likely to adhere due to condensation, etc.

Handling

⚠ Caution

Finite orbit type guide is used in the actuator finger part. By using this, when there are inertial force which cause by movements or rotation to the actuator, steel ball will move to one side and this will cause a large resistance and degrade the accuracy. When there are inertial force which cause by movements or rotation to the actuator, operate the finger to full stroke.

How to Mount Air Grippers

Possible to mount from 2 directions

How to mount air grippers

Axial mounting (Body tapped)

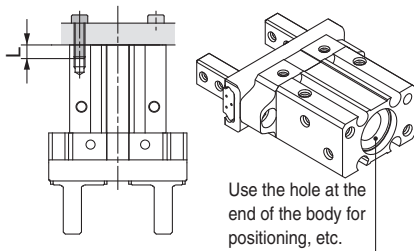

Model	Applicable bolt	Max. tightening torque [N·m]	Max. screw-in depth L [mm]
JMHZ2-8	M3 x 0.5	0.88	6
JMHZ2-12	M3 x 0.5	0.88	6
JMHZ2-16	M4 x 0.7	2.1	8
JMHZ2-20	M5 x 0.8	4.3	10

Model	Hole diameter	Hole depth [mm]
JMHZ2-8	∅ 9H9 ^{+0.036} ₀	2
JMHZ2-12	∅ 13H9 ^{+0.043} ₀	2
JMHZ2-16	∅ 17H9 ^{+0.043} ₀	2
JMHZ2-20	∅ 21H9 ^{+0.052} ₀	3

How to mount air grippers

Lateral mounting (Body tapped and through-holes)

● Body tapped

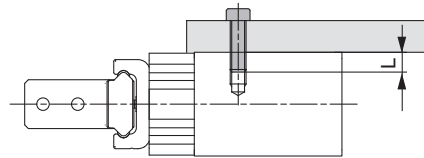

Model	Applicable bolt	Max. tightening torque [N·m]	Max. screw-in depth L [mm]
JMHZ2-8	M3 x 0.5	0.88	6
JMHZ2-12	M3 x 0.5	0.88	6
JMHZ2-16	M4 x 0.7	2.1	8
JMHZ2-20	M5 x 0.8	4.3	10

● Body through-holes

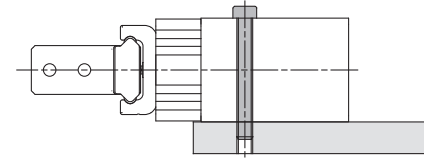

Model	Applicable bolt	Max. tightening torque [N·m]
JMHZ2-8	M2.5 x 0.45	0.31
JMHZ2-12	M2.5 x 0.45	0.31
JMHZ2-16	M3 x 0.5	0.59
JMHZ2-20	M4 x 0.7	1.4

How to mount attachments to the finger

The attachment must be mounted on fingers using bolts such as finger mounting female threads, etc., which should be tightened with the tightening torque in the table below.

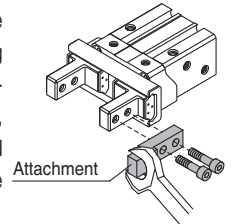

Model	Applicable bolt	Max. tightening torque [N·m]
JMHZ2-8	M2.5 x 0.45	0.31
JMHZ2-12	M2.5 x 0.45	0.31
JMHZ2-16	M3 x 0.5	0.59
JMHZ2-20	M4 x 0.7	1.4

Considerations for attachment mass

A long or heavy attachment increases the inertia force required to open or close the fingers. This may cause unsteady movement of fingers and decrease the life of the gripper. Design the attachment as short and light as possible referring to the mass specified in the table below.

Model	Attachment mass (One side) [g]
JMHZ2-8	18
JMHZ2-12	35
JMHZ2-16	70
JMHZ2-20	140

Precautions when Using Elbow Fittings

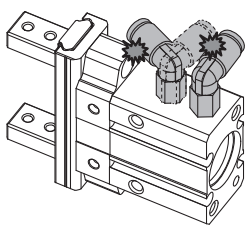

When elbow piping fittings are used, they may interfere with each other or part of gripper, limiting the range for piping entry. Please use extended male elbow, KQ 2 W, or extension fittings listed in the table below to avoid this situation.

Model	Extension fitting
JMHZ2-8	P3311176A
JMHZ2-12	
JMHZ2-16	P3311276A
JMHZ2-20	

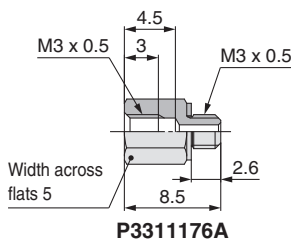

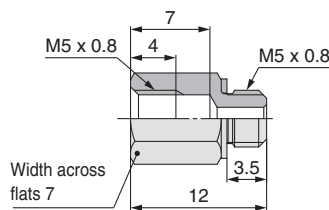

P3311176A



P3311276A

Safety Instructions

These safety instructions are intended to prevent hazardous situations and/or equipment damage. These instructions indicate the level of potential hazard with the labels of “Caution,” “Warning” or “Danger.” They are all important notes for safety and must be followed in addition to International Standards (ISO/IEC)¹⁾, and other safety regulations.

	Caution: Caution indicates a hazard with a low level of risk which, if not avoided, could result in minor or moderate injury.
	Warning: Warning indicates a hazard with a medium level of risk which, if not avoided, could result in death or serious injury.
	Danger: Danger indicates a hazard with a high level of risk which, if not avoided, will result in death or serious injury.

- 1) ISO 4414: Pneumatic fluid power – General rules relating to systems.
ISO 4413: Hydraulic fluid power – General rules relating to systems.
IEC 60204-1: Safety of machinery – Electrical equipment of machines.
(Part 1: General requirements)
ISO 10218-1: Manipulating industrial robots - Safety.
etc.

Warning

1. The compatibility of the product is the responsibility of the person who designs the equipment or decides its specifications.

Since the product specified here is used under various operating conditions, its compatibility with specific equipment must be decided by the person who designs the equipment or decides its specifications based on necessary analysis and test results. The expected performance and safety assurance of the equipment will be the responsibility of the person who has determined its compatibility with the product. This person should also continuously review all specifications of the product referring to its latest catalogue information, with a view to giving due consideration to any possibility of equipment failure when configuring the equipment.

2. Only personnel with appropriate training should operate machinery and equipment.

The product specified here may become unsafe if handled incorrectly. The assembly, operation and maintenance of machines or equipment including our products must be performed by an operator who is appropriately trained and experienced.

3. Do not service or attempt to remove product and machinery/equipment until safety is confirmed.

1. The inspection and maintenance of machinery/equipment should only be performed after measures to prevent falling or runaway of the driven objects have been confirmed.
2. When the product is to be removed, confirm that the safety measures as mentioned above are implemented and the power from any appropriate source is cut, and read and understand the specific product precautions of all relevant products carefully.
3. Before machinery/equipment is restarted, take measures to prevent unexpected operation and malfunction.

4. Contact SMC beforehand and take special consideration of safety measures if the product is to be used in any of the following conditions.

1. Conditions and environments outside of the given specifications, or use outdoors or in a place exposed to direct sunlight.
2. Installation on equipment in conjunction with atomic energy, railways, air navigation, space, shipping, vehicles, military, medical treatment, combustion and recreation, or equipment in contact with food and beverages, emergency stop circuits, clutch and brake circuits in press applications, safety equipment or other applications unsuitable for the standard specifications described in the product catalogue.
3. An application which could have negative effects on people, property, or animals requiring special safety analysis.
4. Use in an interlock circuit, which requires the provision of double interlock for possible failure by using a mechanical protective function, and periodical checks to confirm proper operation.

Caution

1. The product is provided for use in manufacturing industries.

The product herein described is basically provided for peaceful use in manufacturing industries.
If considering using the product in other industries, consult SMC beforehand and exchange specifications or a contract if necessary.
If anything is unclear, contact your nearest sales branch.

Limited warranty and Disclaimer/Compliance Requirements

The product used is subject to the following “Limited warranty and Disclaimer” and “Compliance Requirements”. Read and accept them before using the product.

Limited warranty and Disclaimer

1. The warranty period of the product is 1 year in service or 1.5 years after the product is delivered, whichever is first.²⁾ Also, the product may have specified durability, running distance or replacement parts. Please consult your nearest sales branch.
 2. For any failure or damage reported within the warranty period which is clearly our responsibility, a replacement product or necessary parts will be provided. This limited warranty applies only to our product independently, and not to any other damage incurred due to the failure of the product.
 3. Prior to using SMC products, please read and understand the warranty terms and disclaimers noted in the specified catalogue for the particular products.
- 2) Vacuum pads are excluded from this 1 year warranty.
A vacuum pad is a consumable part, so it is warranted for a year after it is delivered. Also, even within the warranty period, the wear of a product due to the use of the vacuum pad or failure due to the deterioration of rubber material are not covered by the limited warranty.

Compliance Requirements

1. The use of SMC products with production equipment for the manufacture of weapons of mass destruction (WMD) or any other weapon is strictly prohibited.
2. The exports of SMC products or technology from one country to another are governed by the relevant security laws and regulations of the countries involved in the transaction. Prior to the shipment of a SMC product to another country, assure that all local rules governing that export are known and followed.

Caution

SMC products are not intended for use as instruments for legal metrology.

Measurement instruments that SMC manufactures or sells have not been qualified by type approval tests relevant to the metrology (measurement) laws of each country.
Therefore, SMC products cannot be used for business or certification ordained by the metrology (measurement) laws of each country.

Safety Instructions

Be sure to read “Handling Precautions for SMC Products” (M-E03-3) before using.

SMC Corporation (Europe)

Austria	+43 (0)2262622800	www.smc.at	office@smc.at
Belgium	+32 (0)33551464	www.smc.be	info@smc.be
Bulgaria	+359 (0)2807670	www.smc.bg	office@smc.bg
Croatia	+385 (0)13707288	www.smc.hr	office@smc.hr
Czech Republic	+420 541424611	www.smc.cz	office@smc.cz
Denmark	+45 70252900	www.smc.dk.com	smc@smcdk.com
Estonia	+372 6510370	www.smc.pneumatics.ee	smc@info@smcee.ee
Finland	+358 207513513	www.smc.fi	smc@info@smc.fi
France	+33 (0)164761000	www.smc-france.fr	info@smc-france.fr
Germany	+49 (0)61034020	www.smc.de	info@smc.de
Greece	+30 210 2717265	www.smchellas.gr	sales@smchellas.gr
Hungary	+36 23513000	www.smc.hu	office@smc.hu
Ireland	+353 (0)14039000	www.smcautomation.ie	sales@smcautomation.ie
Italy	+39 03990691	www.smc.italia.it	mailbox@smc.italia.it
Latvia	+371 67817700	www.smc.lv	info@smc.lv

Lithuania	+370 5 2308118	www.smclt.lt	info@smclt.lt
Netherlands	+31 (0)205318888	www.smc.nl	info@smc.nl
Norway	+47 67129020	www.smc-norge.no	post@smc-norge.no
Poland	+48 222119600	www.smc.pl	office@smc.pl
Portugal	+351 214724500	www.smc.eu	apoioclientept@smc.smces.es
Romania	+40 213205111	www.smcromania.ro	smcromania@smcromania.ro
Russia	+7 (812)3036600	www.smc.eu	sales@smcru.com
Slovakia	+421 (0)413213212	www.smc.sk	office@smc.sk
Slovenia	+386 (0)73885412	www.smc.si	office@smc.si
Spain	+34 945184100	www.smc.eu	post@smc.smces.es
Sweden	+46 (0)86031240	www.smc.nu	smc@smc.nu
Switzerland	+41 (0)523963131	www.smc.ch	info@smc.ch
Turkey	+90 212 489 0 440	www.smc.pnomatik.com.tr	info@smc.pnomatik.com.tr
UK	+44 (0)845 121 5122	www.smc.uk	sales@smc.uk

South Africa +27 10 900 1233 www.smcza.co.za zasales@smcza.co.za