

MANUAL

VGSTTM3010

B75P, BF80P, BF110P, BL 30-3P, BL 40-3P, BL 40-4, BL 40-5, BX35P, BX52P, BX75P, BX110P, F75P, F110P, FC50P, FC75P, FC100P, OB35x90P, OB50x140P, OB65x170P, OBL40x90P, OF25x70P, OF40x110P, OF55x150P, OF70x175P

Piab gives you service all over the world.
To find your local distributor, please visit www.piab.com.

No need to compromise



www.piab.com

Art. No. 0107479, Rev.05
Piab AB, 2015-03



(GB) Safety
(DK) Advarselsymboler
(DE) Warnsymbole
(ES) Señales de advertencia

(FR) Sécurité
(IT) Segnali di avvertenza
(NL) Waarschuwingsymbolen
(NO) Sikkerhet

(PT) Sinais Avisadores
(SV) Säkerhet
(FI) Varoitusmerkit
(日) 安全性に関して

(GB) Warranty
(DK) Garanti
(DE) Garantie
(ES) Garantía

(FR) Garantie
(IT) Garanzia
(NL) Garantie
(NO) Garanti

(PT) Garantia
(SE) Garanti
(FI) Takuu
(日) 保証に関して



- Vacuum force
- Vakuumkraft
- Vakuumkraft
- Fuerza de vacío
- Force d'aspiration
- Potenza di aspirazione
- Vacuumkracht
- Vakuumkraft
- Vácuo ligado
- Vakuumkraft
- Voimakas imu
- 真空力

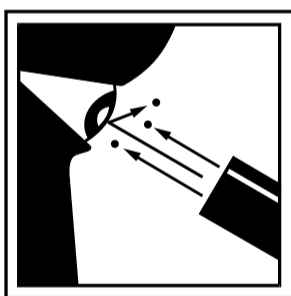

- Exhaust
- Udblæs
- Abluft
- Aire procedente
- Evacuation de l'air
- Aria di scarico
- Uitlaatlucht
- Eksos
- Salida de ar
- Utblås
- Poistoilma
- 排気



- Unrestricted exhaust
- Forbudt blokere udblæsningen
- Abluft nicht blockieren
- Prohibido bloquear la salida del aire
- Interdit de bloquer l'évacuation de l'air
- Lo scarico della pompa non deve essere ostruito
- Pompuitlaat vrijhouden
- Forbudt å blokkere eksos
- O escape da bomba deve ser livre
- Förbjudet blockera utblås
- Ulospuhalluksen esto kielletty
- 吸排気口を自由にする

(GB) The Piab Vacuum Pump has a 5 year warranty against manufacturing defects. The warranty is valid for the vacuum pump only and covers no other costs.

(DK) Piab vakuumpumper har 5 års garanti mod fabriktionsfejl. Garantien gælder kun vakuumpumperne, men ikke andre omkostninger eller fragtomkostninger.

(DE) Bei Herstellungsfehlern an der Piab Vakuumpumpe geben wir 5 Jahre Garantie. Verschleißteile wie z.B. Filter sind ausgeschlossen.

(ES) La bomba de vacío Piab tiene una garantía de 5 años contra defectos de fabricación. La garantía es válida para la bomba de vacío solamente sin cubrir gastos extras.

(FR) La pompe à vide Piab est garantie 5 ans contre les défauts de fabrication. La garantie est valable uniquement pour la pompe, et ne couvre pas d'autres frais, par exemple les frais d'expédition.

(IT) La pompa a vuoto Piab ha 5 anni di garanzia contro i difetti di fabbricazione. La garanzia e' valida solo per la pompa a vuoto e non copre altri costi.

(NL) Piab vacuümpompen hebben een garantietermijn tegen fabricagefouten van 5 jaar. De garantie geldt alleen voor de pomp en dekt geen andere kosten.

(NO) Piab Vakuumpumper har 5 års garanti mot fabriktionsfeil. Garantien gjelder kun vakuumpumpen og dekker ikke andre kostnader eller fraktkostnader.

(PT) As bombas de vacuo Piab têm 5 anos de garantia contra defeitos de fabrico. A garantia e' válida somente para as bombas de vacuo não cobrindo outros custos.

(SE) Piab Vakuumpump har 5 års garanti mot fabriktionsfel. Garantien omfattar enbart vakuumpumpen och täcker ej andra kostnader eller fraktkostnader.

(FI) Piab-tyhjäpumpuilla on 5-vuoden takuu koskien valmistusvirheitä. Takuu koskee ainoastaan tyhjäpumpua, eikä peitä muita kustannuksia taikka lähetyskuluja.

(日) 本製品の保証は製造上の欠陥のみを対象とし、輸送中の破損やその他の費用は保証範囲外です。

1. INSTALLATION/CONNECTIONS

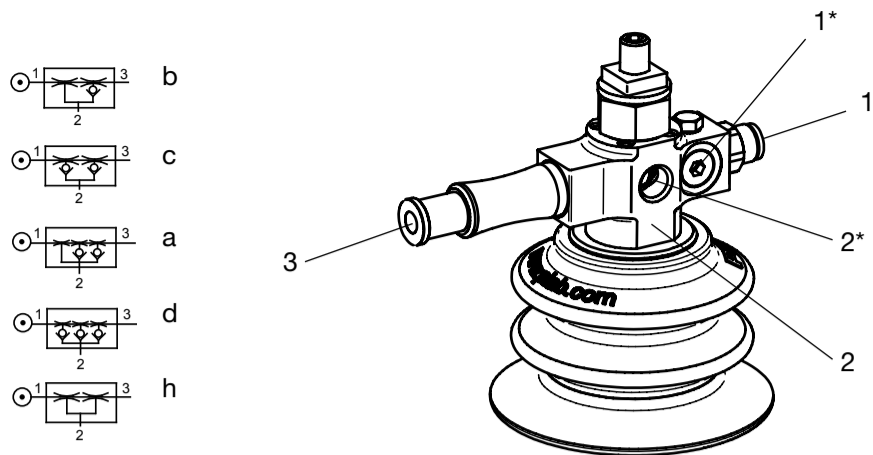

RECOMMENDED HOSE DIMENSIONS IN MM [IN.] (INTERNAL DIAMETER)

Connections		COAX® cartridge
		Di16-2, Pi12-2, Pi12-3, Si08-2, Si08-3, Xi10-2, Xi10-3
1	Compressed air	≥4 [≥0.16]
2	Vacuum	≥8 [≥0.31]
3	Exhaust	≥10 [≥0.39]

*Sensing ports. Applies to hoses up to 2 m [6.6 feet]

FEED PRESSURE, VACUUM LEVEL AND EXHAUST PRESSURE

COAX® cartridge	Feed pressure* MPa [psi]	Max. vacuum -kPa [-inHg]	Max. exhaust pressure MPa [psi]
Di16-2	0.6 [87]	73 [21.6]	N.A.
Pi12-2, Pi12-3	0.34 [49.3]	90 [26.6]	0.13 [18.9]
Si08-2, Si08-3	0.6 [87]	75 [22.2]	0.07 [10.2]
Xi10-2, Xi10-3	0.5 [72.5]	94 [27.7]	0.09 [13.1]

*Feed pressure tolerance +0.00/-0.02 MPa

2. MOUNTING

ALT. 1

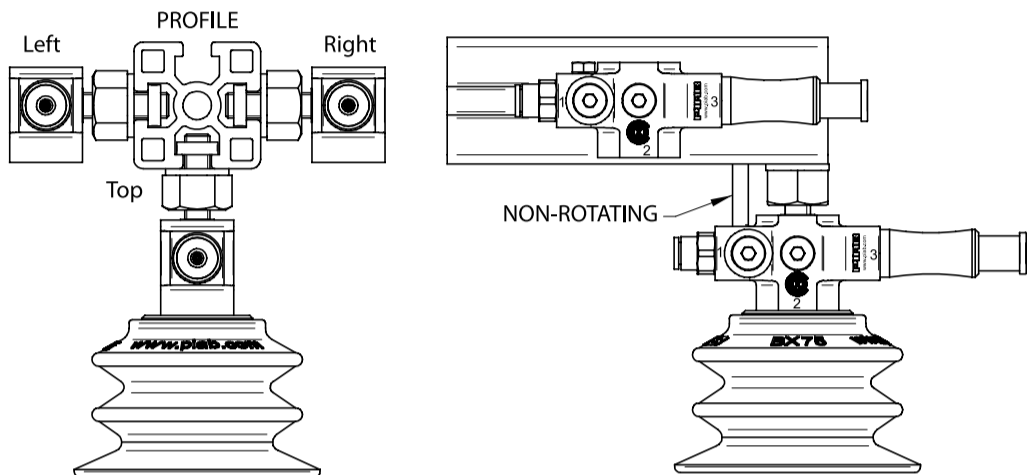

ALT. 2

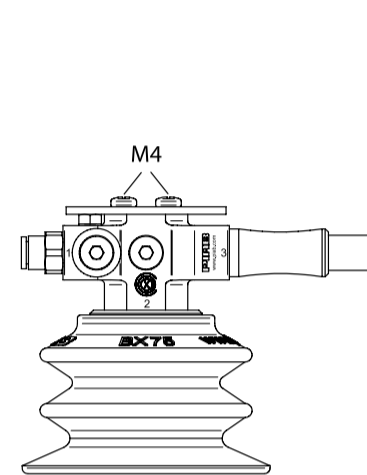

3. DIMENSIONS

VGSTTM3010 WITH COAX® CARTRIDGE

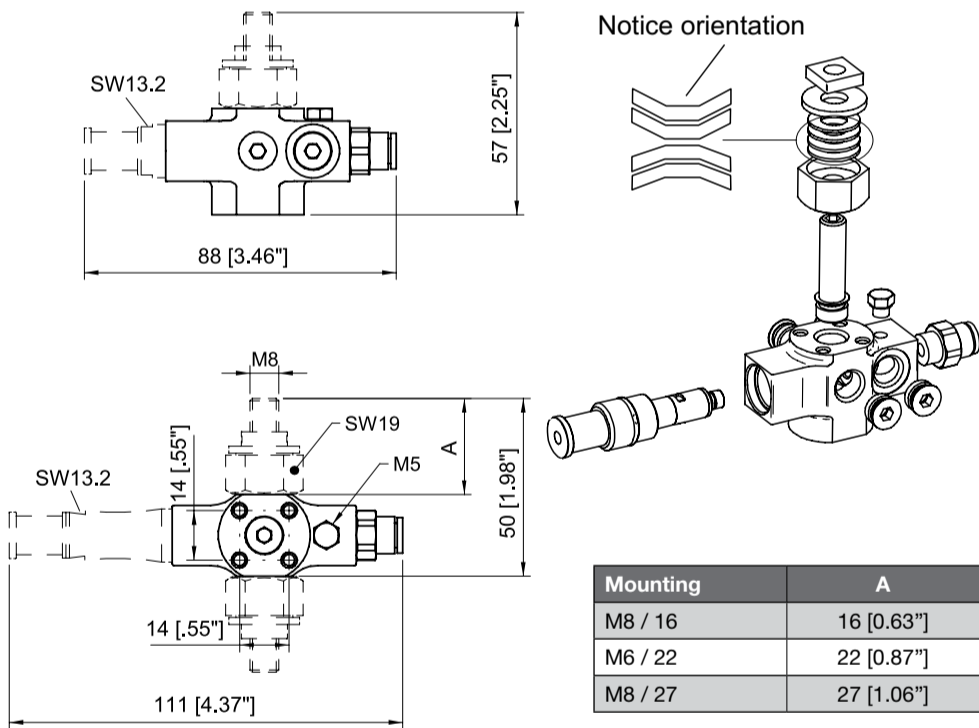

4. SPARE PARTS

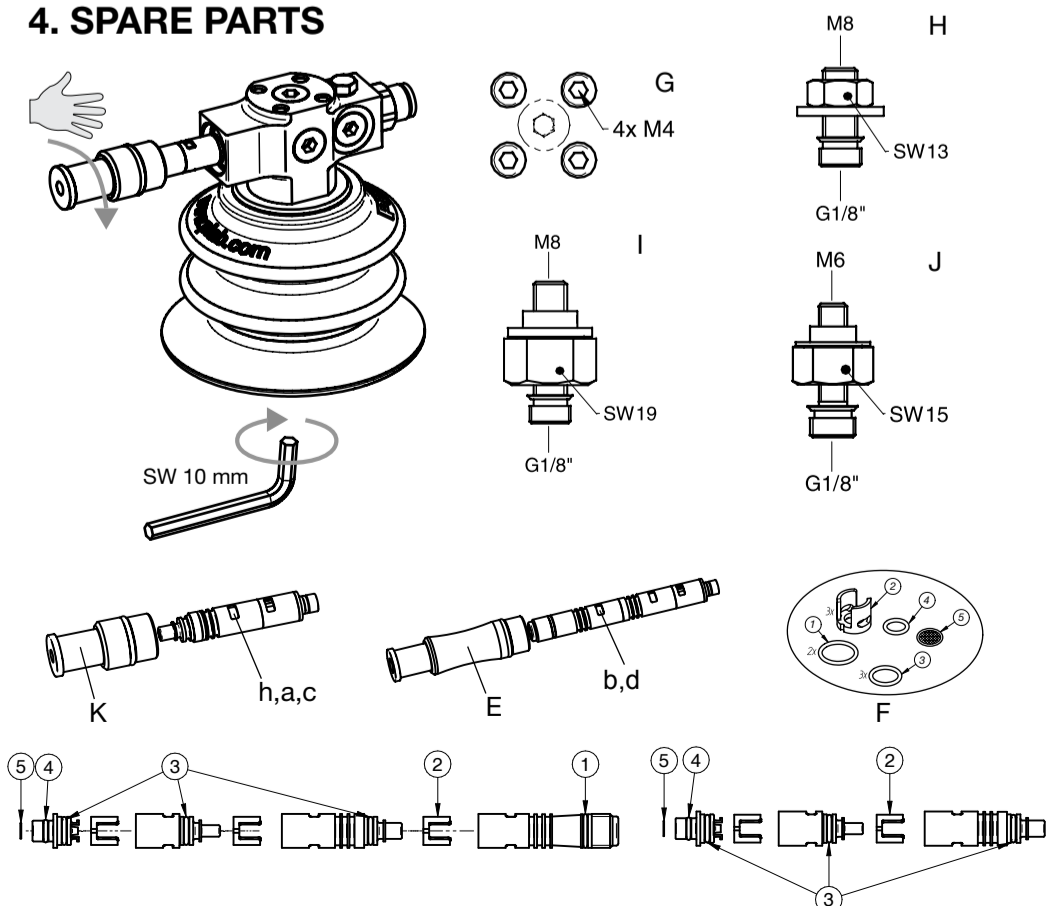

Pos	Description	Art. No.
h	COAX® cartridge MINI Di16-2	0204917
b	COAX® cartridge MINI Pi12-2	0106922
c	COAX® cartridge MINI Pi12-2 extra non-return valve	0106963
b	COAX® cartridge MINI Si08-2	0113583
c	COAX® cartridge MINI Si08-2 extra non-return valve	0113587
b	COAX® cartridge MINI Xi10-2	0120284
c	COAX® cartridge MINI Xi10-2 extra non-return valve	0120280
a	COAX® cartridge MINI Pi12-3	0106895
d	COAX® cartridge MINI Pi12-3 extra non-return valve	0106956
a	COAX® cartridge MINI Si08-3	0113214
d	COAX® cartridge MINI Si08-3 extra non-return valve	0113575
a	COAX® cartridge MINI Xi10-3	0120286
d	COAX® cartridge MINI Xi10-3 extra non-return valve	0120289
K	Cartridge holder MINI, 2cpl	0106921
E	Cartridge holder MINI, 3cpl	0106896
F	Spare part kit COAX® cartridge MINI	0109532
G	Mounting kit 4xM4	0106915
H	Mounting kit M8/10	0106927
I	Mounting kit M8/27	0106949
J	Mounting kit M6/22	0108488