

Piab gives you service all over the world.
To find your local distributor, please visit www.piab.com.

No need to compromise.

www.piab.com

Art. No. 0117659, Rev. 08
Piab AB, 2015-05 / Printed in Sweden by Elanders

MANUAL

Vacuum pump P6040



(GB) Safety
(DK) Advarselsymboler
(DE) Warnsymbole
(ES) Señales de advertencia

(FR) Sécurité
(IT) Segnali di avvertenza
(NL) Waarschuwingsymbolen
(NO) Sikkerhet

(PT) Sinais Avisadores
(SV) Säkerhet
(FI) Varoitusmerkit
(日) 安全性

(GB) Warranty
(DK) Garanti
(DE) Garantie
(ES) Garantía

(FR) Garantie
(IT) Garanzia
(NL) Garantie
(NO) Garanti

(PT) Garantia
(SE) Garanti
(FI) Takuu
(日) 保証に関して



- Vacuum force
- Vakuumkraft
- Vakuumkraft
- Fuerza de vacío
- Force d'aspiration
- Potenza di aspirazione
- Vacuumkracht
- Vakuumkraft
- Vácuo ligado
- Vakuumkraft
- Voimakas imu
- 真空力

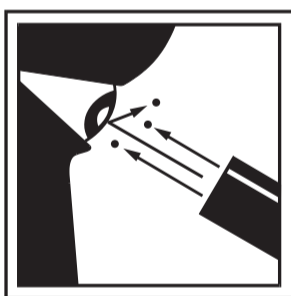

- Exhaust
- Udblæs
- Abluft
- Aire procedente
- Evacuation de l'air
- Aria di scarico
- Uitlaatlucht
- Eksos
- Saida de ar
- Utblås
- Poistoilma
- 排気



- Unrestricted exhaust
- Forbudt blokere udblæsningen
- Abluft nicht blockieren
- Prohibido bloquear la salida del aire
- Interdit de bloquer l'évacuation de l'air
- Lo scarico della pompa non deve essere ostruito
- Pompuitlaat vrijhouden
- Forbudt å blokkere eksos
- O escape da bomba deve ser livre
- Förbjudet blockera utblås
- Ulospuhalluksen esto kielletty
- 排気口を塞がないで下さい。

(GB) The Piab Vacuum Pump has a 5 year warranty against manufacturing defects. The warranty is valid for the vacuum pump only and covers no other costs.

(DK) Piab vakuumpumper har 5 års garanti mod fabriktionsfej. Garantien gælder kun vakuumpumperne, men ikke andre omkostninger eller fragtomkostninger.

(DE) Bei Herstellungsfehlern an der Piab Vakuumpumpe geben wir 5 Jahre Garantie. Verschleißteile wie z.B. Filter sind ausgeschlossen.

(ES) La bomba de vacío Piab tiene una garantía de 5 años contra defectos de fabricación. La garantía es válida para la bomba de vacío solamente sin cubrir gastos extras.

(FR) La pompe à vide Piab est garantie 5 ans contre les défauts de fabrication. La garantie est valable uniquement pour la pompe, et ne couvre pas d'autres frais, par exemple les frais d'expédition.

(IT) La pompa a vuoto Piab ha 5 anni di garanzia contro i difetti di fabbricazione. La garanzia e' valida solo per la pompa a vuoto e non copre altri costi.

(NL) Piab vacuümpompen hebben een garantietermijn tegen fabricagefouten van 5 jaar. De garantie geldt alleen voor de pomp en dekt geen andere kosten.

(NO) Piab Vakuumpumper har 5 års garanti mot fabriktionsfeil. Garantien gjelder kun vakuumpumpen og dekker ikke andre kostnader eller fraktkostnader.

(PT) As bombas de vacuo Piab têm 5 anos de garantia contra defeitos de fabrico. A garantia e' válida somente para as bombas de vacuo não cobrindo outros custos.

(SE) Piab Vakuumpump har 5 års garanti mot fabriktionsfel. Garantien omfattar enbart vakuumpumpen och täcker ej andra kostnader eller fraktkostnader.

(FI) Piab-tyhjöpumpuilla on 5-vuoden takuu koskien valmistusvirheitä. Takuu koskee ainoastaan tyhjöpumpua, eikä peitä muita kustannuksia taikka lähetyskuluja.

(日) ピアブのポンプには製造上の欠陥に限り五年間の保証があります。保証はポンプのみ有効です。

1. INSTALLATION/CONNECTION

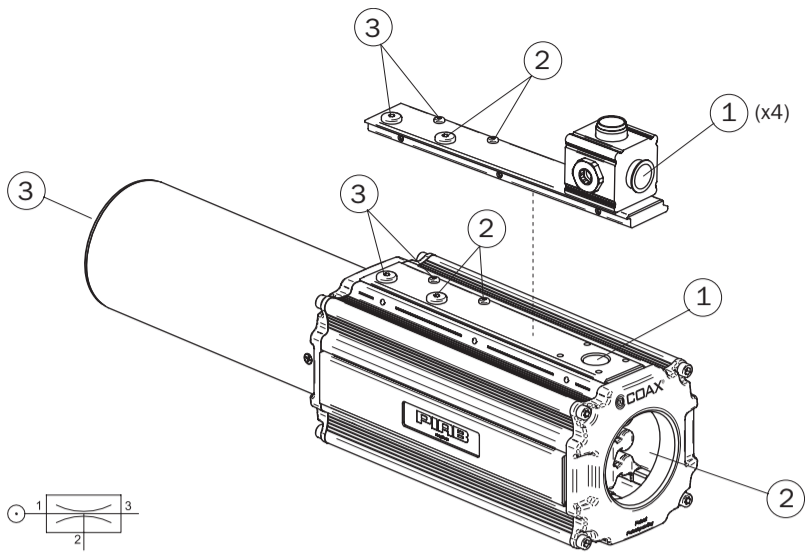

FEED PRESSURE, VACUUM LEVEL AND EXHAUST PRESSURE

COAX® cartridge	Feed pressure MPa [psi]	Max. vacuum -kPa [-inHg]	Max. exhaust pressure MPa [psi]
Pi	0.3 [43.5]	90 [26.6]	0.14 [20.3]
Si	0.6 [87]	75 [22]	0.08 [11.6]
Xi	0.45 [65]	96 [28]	0.09 [13.1]

RECOMMENDED HOSE DIMENSIONS IN MM [IN.] (INTERNAL DIAMETER)

Connections	COAX® cartridge Pi				
	7/8	9/10	11/12	13/14	15/16
1. Compressed air	>11 [0.43]	>11 [0.43]	>12 [0.47]	>13 [0.51]	>14 [0.55]
2. Vacuum	>35 [1.38]	>40 [1.57]	>40 [1.57]	>40 [1.57]	>45 [1.77]
3. Exhaust	>40 [1.57]	>45 [1.77]	>50 [1.97]	>55 [2.17]	>60 [2.36]

Applies to hoses up to 2 m (6.6 feet) long.

Connections	COAX® cartridge Si				
	7/8	9/10	11/12	13/14	15/16
1. Compressed air	>8 [0.31]	>9 [0.35]	>10 [0.39]	>10 [0.39]	>11 [0.43]
2. Vacuum	>35 [1.38]	>40 [1.57]	>40 [1.57]	>45 [1.77]	>45 [1.77]
3. Exhaust	>40 [1.57]	>40 [1.57]	>50 [1.97]	>50 [1.97]	>50 [1.97]

Applies to hoses up to 2 m (6.6 feet) long.

Connections	COAX® cartridge Xi				
	7/8	9/10	11/12	13/14	15/16
1. Compressed air	>8 [0.31]	>9 [0.35]	>10 [0.39]	>10 [0.39]	>11 [0.43]
2. Vacuum	>35 [1.38]	>40 [1.57]	>40 [1.57]	>45 [1.77]	>45 [1.77]
3. Exhaust	>40 [1.57]	>40 [1.57]	>50 [1.97]	>50 [1.97]	>50 [1.97]

Applies to hoses up to 2 m (6.6 feet) long.

2. MOUNTING

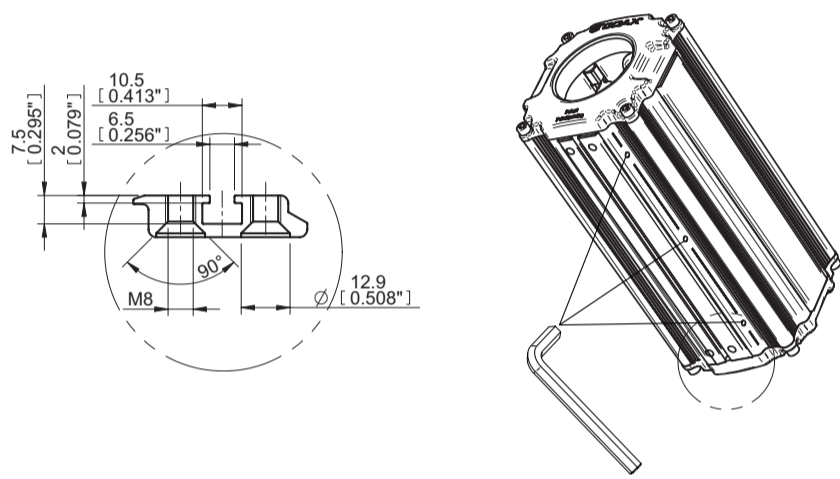

3. DIMENSIONS

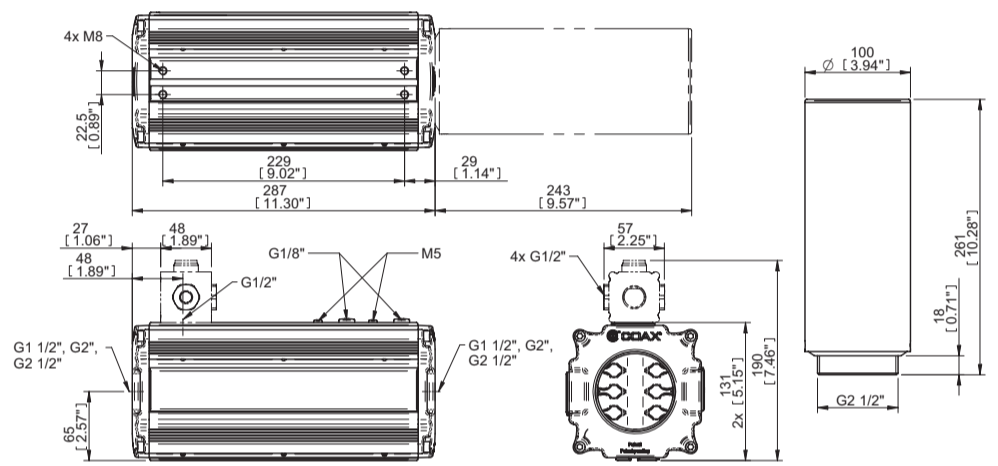

4. SPARE PARTS

DISASSEMBLY order 1-> 2 -> 3

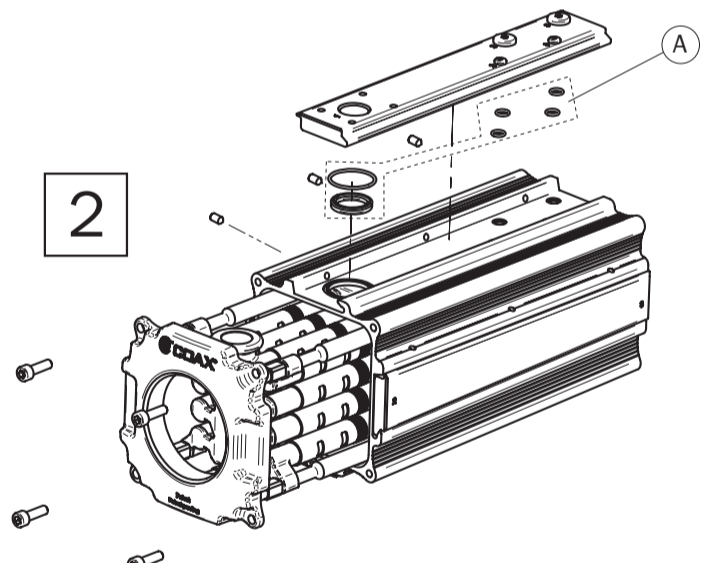
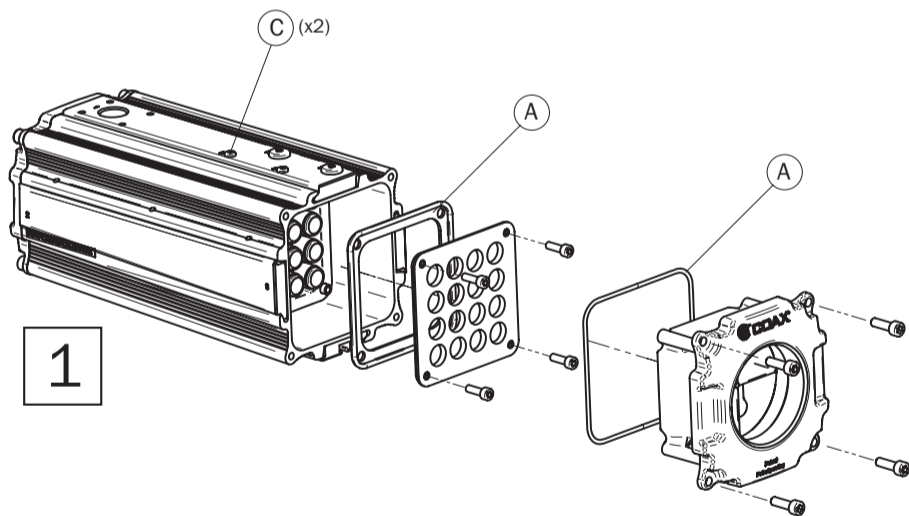

Pos.	Description	Art. No.
A	Spare part kit P6040	0117780
B	Spare part kit Midi COAX®	0109531
C	Plug M5 cpl. x1	0106553
D	Air distributor, P6040	0117133
	Cover plate 4xG1/2", P6040	0117786
	Cover plate G1/2", P6040	0117787
	COAX® Cartridge Midi Pi48-3	0106639
	COAX® Cartridge Midi Pi48-3, extra non-return valve	0107714
F	COAX® Cartridge Midi Pi48-3, 1x flapvalve	0201849
	COAX® Cartridge Midi Si32-3	0107053
E	COAX® Cartridge Midi Si32-3, extra non-return valve	0107713
F	COAX® Cartridge Midi Si32-3, 1x flapvalve	0201848
	COAX® Cartridge Midi Xi40-3	0118724
	COAX® Cartridge Midi Xi40-3, extra non-return valve	0118725
F	COAX® Cartridge Midi Xi40-3, 1x flapvalve	0201847
	Blind Cartridge Midi-3	0112527

