

QO LINE



cmatic[®]
P N E U M A T I C F I T T I N G S

Raccordi Automatici per Oleodinamica, 350 bar
Push-in Fittings for Hydraulics, 350 bar
Raccords instantanés pour l'hydraulique, 350 bar
Steckverschraubungen für die Hydraulik, 350 bar



Raccordi Automatici sviluppati e testati per resistere ad una pressione di lavoro di 350 bar. Il design compatto ed innovativo permette montaggi veloci, semplici e sicuri senza l'ausilio di utensili, su superfici ridotte o durante operazioni d'assemblaggio difficoltose.

La tenuta idraulica tra il raccordo e l'innesto avviene tramite una guarnizione esterna al raccordo permettendone la manutenzione in caso di danneggiamento o usura.

Push-in fittings designed and tested to guarantee a working pressure of 350 bar. The compact, innovative design allows for safe, quick and easy assemblies with no need for assembly tools on reduced manifold spaces as well as during difficult assembly operations. The hydraulic tightness between the fitting and the plug is guaranteed by an oring outside of the fitting itself. This feature enables the fitting serviceability in case of oring damage or wear out.



Raccords instantanés conçus et testés pour garantir une pression de travail de 350 bars. La conception compacte et innovante permet des assemblages sûrs, rapides et faciles sans outils de montage sur des espaces réduits et pendant toutes opérations de montage difficile. L'étanchéité hydraulique entre le raccord et l'embout est garantie par un joint torique situé à l'extérieur du raccord. Cette caractéristique permet de faciliter l'entretien des raccords en cas de dommage ou d'usure du joint torique.



Steckverschraubungen, entwickelt und getestet, um einen Betriebsdruck von 350 bar zu gewährleisten. Das kompakte, innovative Design ermöglicht eine sichere, schnelle und einfache Montage ohne Werkzeuge bei Verteilern und bei schwierigen Montagevorgängen. Die hydraulische Dichtheit zwischen der Verschraubung und dem Stecker wird durch eine Dichtung außerhalb der Verschraubung selbst gewährleistet. Dieses Merkmal ermöglicht die Wartung der Verschraubung bei Beschädigungen oder beim Verschleiß der Dichtung.



00 1 - 2	3	4	5	6
Corpo e Pinza di Aggraffaggio Body and Gripping ring Corps et Pince Körper und Spannzange	Estrattore Release Ring Poussoir Lösering	Anello di Sicurezza Safety Ring Bague sécurité Sicherheitsring	Guarnizioni Seals Joint d'étanchéité Dichtung	Anello di Backup Backup Ring Bague protection Schutzring
Acciaio Zincato 11SMnPb37 Zinc plated steel 11SMnPb37 Acier zingué 11SMnPb37 Stahl verzinkt 11SMnPb37	Acciaio Zincato 11SMnPb37 Zinc plated steel 11SMnPb37 Acier zingué 11SMnPb37 Stahl verzinkt 11SMnPb37	PA66	NBR 90 Sh	PTFE



-30°C + 100°C



Max 350 bar

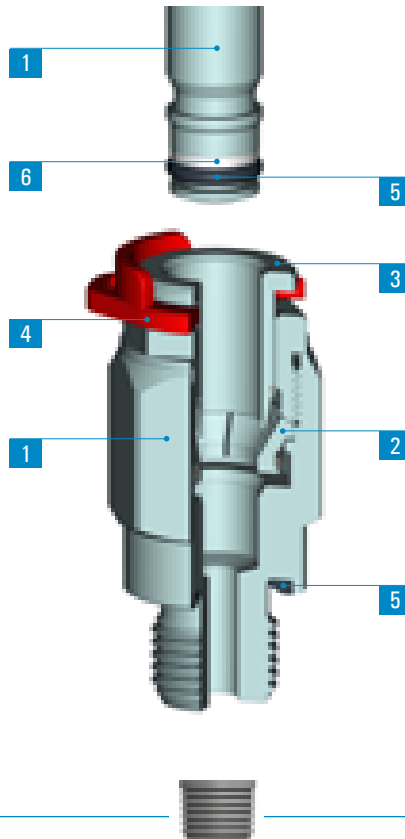

		G1/4	G3/8	G1/2	G3/4	7/16-20	9/16-18	3/4-16	1 1/16-12	M14x1,5	M16x1,5	M18x1,5	M20x1,5
 D A S H*	4	•				•				•			
	6		•				•				•		
	8			•				•				•	
	12				•				•				•

*Dash = 1/16"

SPECIFICHE TECNICHE

Tubi di collegamento consigliati:
Tubo in gomma sintetica resistente all'olio con trecce di rinforzo; la ghiera per fissaggio al terminale sarà in funzione del tipo di tubo.

Campi di applicazione:
Impianti Oleodinamici.

DATA SHEET

Recommended tubings:
Synthetic oil-resistant rubber hose with braids reinforcement; the ferrule for the hose terminal will depend on the hose type.

Application fields:
Hydraulics.

REINSEIGNEMENTS TECHNIQUES

Tubes conseillés:
Tuyau en caoutchouc synthétique résistant à l'huile avec tresses de renforcement; la bague de fixation au raccordement dépendra du type de tuyau.

Domaines d'application:
Hydraulique.

TECHNISCHE AUSKÜNFTE

Empfohlene Schläuche:
Synthetischer ölbeständiger Gummischlauch mit Verstärkungsgeflechten; Die Hülse zur Klemmung an der Schlauchverbindung hängt vom Rohrtyp ab.

Anwendungsbereiche:
Hydraulik.

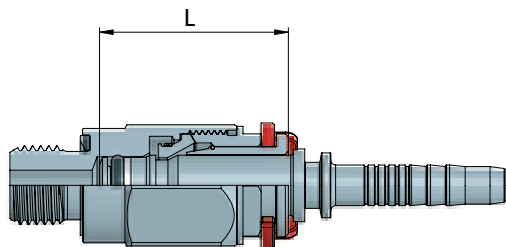

Plug-in DN Dash	L
4	31
6	33,5
8	37,5
12	42

ISTRUZIONI DI MONTAGGIO

1. Verificare che sul terminale siano montati correttamente sia il back-up ring che la guarnizione di tenuta e che siano opportunamente ingrassati;
2. Inserire il terminale all'interno del raccordo spingendolo fino in battuta; l'inserimento del terminale può avvenire anche con l'anello di sicurezza montato sul raccordo.

Estrazione del tubo

1. Rimuovere l'anello di sicurezza inserito tra il corpo del raccordo e l'anello estrattore;
2. Esercitare una leggera pressione sull'anello estrattore estraendo contemporaneamente il terminale dal corpo del raccordo.

ASSEMBLY INSTRUCTIONS

1. Make sure that the back up ring and the tightness ring are assembled and duly greased on the straight hose connection.
2. Push the straight hose connection all the way into the fitting until it bottoms; the hose connection can be assembled also if the safety ring is in place under the release ring.

Tube release

1. Remove the safety ring under the release ring
2. Press the release ring and pull the hose connection out of the fitting.

INSTRUCTIONS DE MONTAGE

1. Assurez-vous que le back up ring et le joint d'étanchéité sont assemblés et graissés sur le raccordement du tube.
2. Poussez le raccordement jusqu'au fond du raccord; la connexion est possible même si la bague de sécurité est en place sous le poussoir du raccord.

Débranchement du tube

1. Retirez la bague de sécurité
2. Appuyez sur la poussoir et retirez le raccordement du tube

MONTAGEANWEISUNGEN

1. Stellen Sie sicher, dass der Stützring und der Dichtring an der Schlauchverbindung montiert und beschmiert sind.
2. Stecken Sie die gerade Schlauchverbindung bis zum Anschlag in die Verschraubung. Die Schlauchverbindung kann auch gemacht werden, wenn der Sicherheitsring an der Verschraubung angebracht ist,

Schlauchlösen

1. Der Sicherheitsring unter dem Verschraubungsloesering entfernen.
2. Auf dem Lösering drücken und die Schlauchverbindung aus der Verschraubung rausziehen.

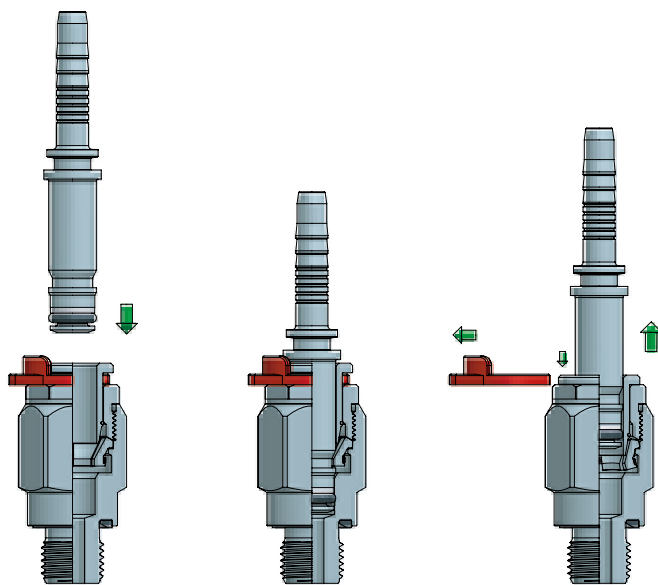

Effettuato il collegamento, assicurarsi che il tubo inserito nel raccordo non sia sottoposto ad alcuna forza di trazione; è necessario inoltre rispettare durante

il collegamento del tubo il raggio minimo di curvatura consigliato così come riportato nella sezione tubi di questo catalogo tecnico (vedi pag. 363)

Al fine di evitare lo sgancio involontario del tubo dal raccordo a causa di una pressione accidentale dell'anello estrattore occorre verificare che l'anello di sicurezza sia sempre montato sul raccordo durante il funzionamento in pressione. L'anello di sicurezza è provvisto di un foro a cui collegare un cavo di fissaggio per evitarne lo smarrimento; in alternativa è disponibile un KIT in cui l'anello di sicurezza viene fornito preassemblato con un cavo per il suo ancoraggio al corpo del raccordo

Per il serraggio delle parti filettate del raccordo si raccomanda di attenersi alle coppie consigliate riportate a pag.6



Once the tubing is connected to the fitting, make sure that the tubing is not subject to any tensile strength and that the min. recommended bending

radius stated in the tubing section of this catalogue is complied with (see page 363).

In order to prevent an involuntary hose disconnection due to an accidental pressure on the fitting release ring, make sure that the safety ring is always in place when the fitting is pressurized. The safety ring shape allows for a fixing wire to be connected. A KIT is also available and it contains the safety ring pre-assembled with the fixing wire. To tighten threads, please check out our tightening torque chart illustrated at page 6.



Une fois effectué le branchement, s'assurer que le tube inséré dans le raccord n'est soumis à aucune force de traction. Egalement, il est nécessaire

de respecter, lors du branchement du tube, le rayon minimum de courbure conseillé dans la section tubes de ce catalogue technique (voir la page 363). Pour éviter toute déconnexion involontaire du tube due à une pression accidentelle sur le poussoir du raccord, assurez-vous que la bague de sécurité est toujours en place lorsque le raccord est sous pression. La forme de la bague de sécurité permet de connecter un fil de fixation. Un KIT est également disponible et contient la bague de sécurité pré-montée avec le fil de fixation. Pour le serrage des parties filettées du raccord, il est recommandé de s'en tenir aux couples de serrage conseillés et reportés à la page 6.



Nach der Schlauchverbindung, sicherstellen, dass der in die Verschraubung eingeführte Schlauch keinen Zugbelastungen ausgesetzt ist; beim Anschluss

des Schlauchs muss der empfohlene Mindestbiegeradius eingehalten werden, gemäß den in diesem technischen Katalog im Schlauchabschnitt, angegebenen Hinweisen (siehe Seite 363).

Um ein ungewolltes Lösen des Schlauchs durch versehentlichen Druck auf den Verschraubungsloesering zu verhindern, stellen Sie sicher, dass der Sicherheitsring immer angebracht ist, wenn die Verschraubung unter Druck steht. Die Sicherheitsringbauform ermöglicht das Anschließen eines Befestigungsdrahtes. Ein KIT ist ebenfalls erhältlich und enthält den mit dem Befestigungsdraht vormontierten Sicherheitsring.

Zum Festziehen der Gewinde sich an den, auf Seite 6, empfohlenen Drehmomente einhalten.

00 12

Raccordo diritto con filetto BSPP

Straight push-in fitting,
BSPP thread

Raccord instantané droit, BSPP

Gerade Steckverschraubung, BSPP

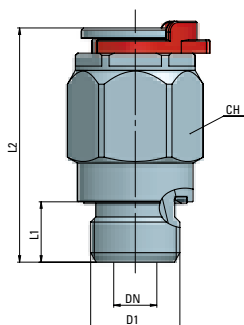

Type	DN Dash	D1	L1	L2	CH	g Δ
12 04 00	04	G1/4	12	46	20	60,9
12 06 00	06	G3/8	12	48	24	85,5
12 08 00	08	G1/2	14	54,4	28	128,7
12 12 00	12	G3/4	16	62,1	38	231,5

BSPP (ISO 1179-2)

00 12

Raccordo diritto con filetto UNF

Straight push-in fitting,
UNF thread

Raccord instantané droit, UNF

Gerade Steckverschraubung, UNF

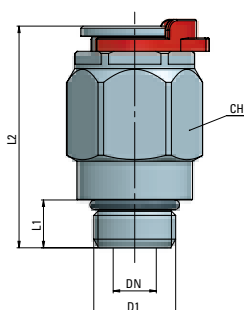

Type	DN Dash	D1	L1	L2	CH	g Δ
12 04 7/16 UNF ORB	04	7/16-20	9,1	42,6	20	-
12 06 9/16 UNF ORB	06	9/16-18	10	45,3	24	-
12 08 3/4-16 UNF ORB	08	3/4-16-16	11,1	51,4	28	-
12 12 1-1/16 UNF ORB	12	1 1/16-12	15,1	60,6	38	-

SAE Oring Boss - UNF Stud (ISO 11926-3)

00 12

Raccordo diritto con filetto metrico

Straight push-in fitting, metric

Raccord instantané droit, filetage métrique

Gerade Steckverschraubung,
metrisch

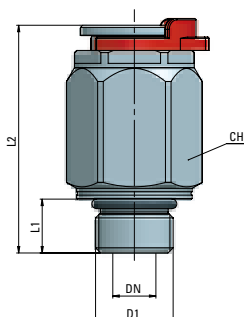

Type	DN Dash	D1	L1	L2	CH	g Δ
12 04 M14x1,5	04	M14x1,5	11	44	20	36,8
12 06 M16x1,5	06	M16x1,5	11,5	46,7	24	84,7
12 08 M18x1,5	08	M18x1,5	12,5	52,9	28	79,3
12 12 M22x1,5	12	M22x1,5	13	60,1	38	-

Metric Stud (ISO 6149-3)

00 90

Terminale diritto

Hose connection, straight

Raccordement tube, droit

Gerade Schlauchverbindung

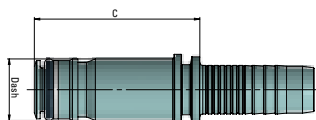

Type	DN Dash	Hose ID (inch)	Hose ID (mm)	C CUT OFF (mm)	g Δ
90 04 1/4	04	1/4	6,2	38,2	21,6
90 06 3/8	06	3/8	9,5	40,3	38,2
90 08 1/2	08	1/2	12,9	45,6	64,3
90 12 3/4	12	3/4	19	52,1	132,5

Corpo in Acciaio indurito e zincato 11SMnPb37 - Body in Hardened Zinc plated steel 11SMnPb37 - Corps en Acier trempé et zingué 11SMnPb37 - Körper aus Stahl gehärtet und verzinkt 11SMnPb37



Al primo inserimento assicurarsi che la guarnizione presente sull'innesto sia adeguatamente lubrificata e/o ingrassata.



During the first assembly, make sure that the oring on the plug is well lubricated/greased.



Pendant le premier montage se rassurer que le joint sur l'embout soit bien lubrifié/graissé.



Anlaesslich der ersten Montage bitte die Dichtung am Stecker ausreichend schmieren.

Q0 91

Terminale 45°

45° hose connection

Raccordement tube, 45°

45° Schlauchverbindung

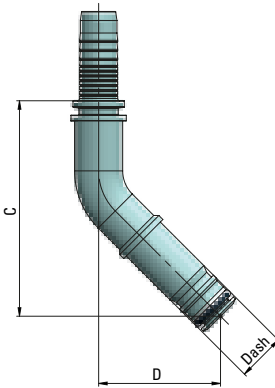

Type	DN Dash	Hose ID (inch)	Hose ID (mm)	C CUT OFF (mm)	D DROP (mm)	g Δ
91 04 1/4	04	1/4	6,2	62,2	37,6	41,7
91 06 3/8	06	3/8	9,5	67,6	40,3	72,3
91 08 1/2	08	1/2	12,9	76	43	122,2
91 12 3/4	12	3/4	19	97,5	56,4	275

Corpo in Acciaio indurito e zincato 11SMnPb37 - Body in Hardened Zinc plated steel 11SMnPb37 - Corps en Acier trempé et zingué 11SMnPb37 - Körper aus Stahl gehärtet und verzinkt 11SMnPb37



Al primo inserimento assicurarsi che la guarnizione presente sull'innesto sia adeguatamente lubrificata e/o ingrassata.



During the first assembly, make sure that the oring on the plug is well lubricated/greased.



Pendant le premier montage se rassurer que le joint sur l'embout soit bien lubrifié/graissé.



Anlaesslich der ersten Montage bitte die Dichtung am Stecker ausreichend schmieren.

Q0 92

Terminale 90°

90° hose connection

Raccordement tube, 90°

90° Schlauchverbindung

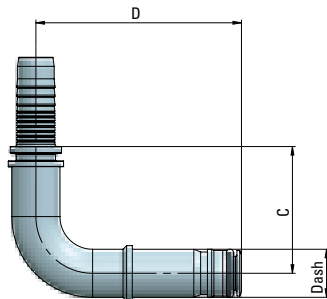

Type	DN Dash	Hose ID (inch)	Hose ID (mm)	C CUT OFF (mm)	D DROP (mm)	g Δ
92 04 1/4	04	1/4	6,2	33,3	62	47,6
92 06 3/8	06	3/8	9,5	37,9	67,5	82,2
92 08 1/2	08	1/2	12,9	44,7	72,5	141,3
92 12 3/4	12	3/4	19	59,8	98,5	327

Corpo in Acciaio indurito e zincato 11SMnPb37 - Body in Hardened Zinc plated steel 11SMnPb37 - Corps en Acier trempé et zingué 11SMnPb37 - Körper aus Stahl gehärtet und verzinkt 11SMnPb37



Al primo inserimento assicurarsi che la guarnizione presente sull'innesto sia adeguatamente lubrificata e/o ingrassata.



During the first assembly, make sure that the oring on the plug is well lubricated/greased.



Pendant le premier montage se rassurer que le joint sur l'embout soit bien lubrifié/graissé.



Anlaesslich der ersten Montage bitte die Dichtung am Stecker ausreichend schmieren.

SAFETY KIT



Type	g Δ
SAFETY KIT DASH 04	-
SAFETY KIT DASH 06	-
SAFETY KIT DASH 08	-
SAFETY KIT DASH 12	-

Raccordo a cartuccia

La cartuccia Q010 è la soluzione ottimale in caso di problemi di ingombro; il design compatto ne permette infatti un montaggio quasi completamente a scomparsa all'interno dei corpi di utilizzo (manifold, valvole, etc...).

Push-in cartridge fitting

The Q010 cartridge is the right solution in case of lack of space; the compact design allows for the assembly of the cartridge in such a way that it almost completely disappears once assembled in its own body (manifolds/ valves etc)

Raccord instantané à cartouche

La cartouche Q010 est la bonne solution en cas de manque d'espace. Le design compacte permet l'assemblage de la cartouche de telle sorte qu'elle disparaît presque complètement une fois assemblée dans son propre corps (collecteurs / vannes, etc.)

Einschraubsteckpatrone

Die Q010-Patrone ist die richtige Lösung beim Platzmangel. Die kompakte Bauweise ermöglicht die Montage der Patrone, so dass sie nach der Montage in ihrem eigenen Körper (Verteiler / Ventile usw.) fast vollständig verschwindet.

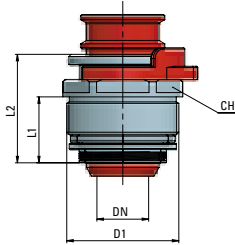

Type	DN Dash	D1	L1	L2	CH	g
10 04 00	04	M18x1	13,2	21,7	17	21,9
10 06 00	06	M22x1	14	23,2	21	32,3
10 08 00	08	M26x1	15,5	25,4	25	47,3
10 12 00	12	M34x1	18,4	27,8	32	81

Schema di foratura

Cartridge seat drilling plan

Plan de forage des cartouches

Patronensitzbohrungskizze

DN (Dash)	D1	D2	D3	D4	L1	L2	L3	L4
04	M18x1	16,2	10,8	9,4	8	10,6	14,4	23,1
06	M22x1	20	14	12,25	8,5	11	15,3	24,3
08	M26x1	24	17,8	16,2	9	12,1	16,9	27,9
12	M34x1	32,2	25	23	12	15	20,6	32,6

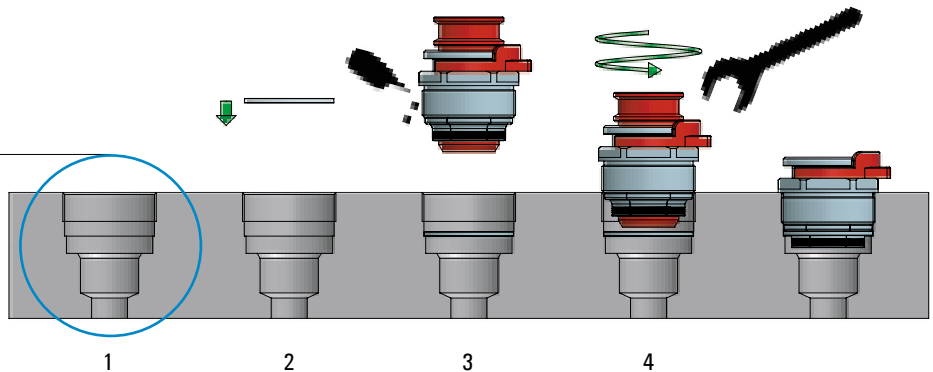
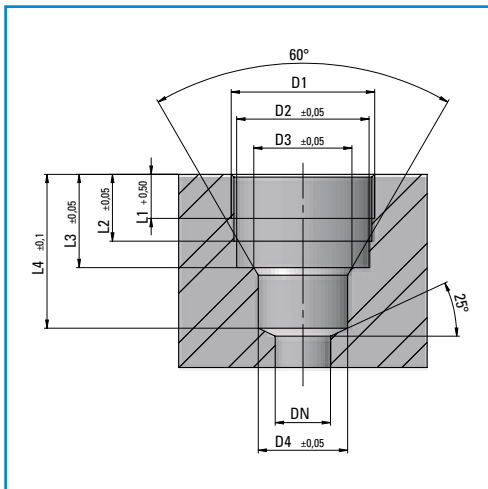

- 1 Realizzare la sede della cartuccia seguendo lo schema dimensionale;
- 2 Inserire il distanziale fornito con la cartuccia sul fondo della sede come riportato in illustrazione;
- 3 Deposare un leggero strato di frenafiletto sul filetto della cartuccia;
- 4 Avvitare la cartuccia nella sua sede assicurandosi di arrivare in battuta.

1. Machine the cartridge seating according to the drawing stated below;
2. Place at the bottom of the seating the distance ring provided with the cartridge, as shown in the picture;
3. Apply a light layer of threadlocking sealant on the cartridge thread;
4. Screw the cartridge all the way into its seating until it bottoms.

1. Usinez le logement de la cartouche conformément au dessin ci-dessous;
2. Placez au fond du logement la bague d'écartement fournie avec la cartouche, comme indiqué sur la photo;
3. Appliquez une légère couche de freinfillet sur le filetage de la cartouche;
4. Vissez la cartouche jusqu'au fond dans son logement.

1. Das Patronengehäuse gemäß der unten angegebenen Zeichnung fertigen;
2. Legen Sie den, mit der Patronen gelieferten Distanzring, im Patronengehäuse gemäß Abbildung;
3. Versehen Sie das Patronengewinde mit einer dünnen Schicht von Schraubensicherung;
4. Schlussendlich ziehen Sie das Patrone in das Gehäuse bis zum Anschlag fest.