

MANUAL

Piab gives you service all over the world.
To find your local distributor, please visit www.piab.com.

No need to compromise.

VGS™5010
BF110P, BL50-3P, BX110P,
BX75P, F110P, OB65x170P



www.piab.com

Art. No. 0110488, Rev.5
Piab AB, 2013-10 / Printed in Sweden by Elanders



(GB) Safety
(DK) Advarselsymboler
(DE) Warnsymbole
(ES) Señales de advertencia

(FR) Sécurité
(IT) Segnali di avvertenza
(NL) Waarschuwingsymbolen
(NO) Sikkerhet

(PT) Sinais Avisadores
(SV) Säkerhet
(FI) Varoitusmerkit
(日) 安全性に関して

(GB) Warranty
(DK) Garanti
(DE) Garantie
(ES) Garantía

(FR) Garantie
(IT) Garanzia
(NL) Garantie
(NO) Garanti

(PT) Garantia
(SE) Garanti
(FI) Takuu
(日) 保証に関して



- Vacuum force
- Vakuumkraft
- Vakuumkraft
- Fuerza de vacío
- Force d'aspiration
- Potenza di aspirazione
- Vakuumkracht
- Vakuumkraft
- Vácuo ligado
- Vakuumkraft
- Voimakas imu
- 真空力

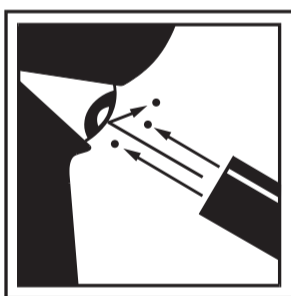

- Exhaust
- Udblæs
- Abluft
- Aire procedente
- Evacuation de l'air
- Aria di scarico
- Uitlaatlucht
- Eksos
- Saida de ar
- Utblås
- Poistoilma
- 排気



- Unrestricted exhaust
- Forbudt blokere udblæsningen
- Abluft nicht blockieren
- Prohibido bloquear la salida del aire
- Interdit de bloquer l'évacuation de l'air
- Lo scarico della pompa non deve essere ostruito
- Pompuitlaat vrijhouden
- Forbudt å blokkere eksos
- O escape da bomba deve ser livre
- Förbjudet blockera utblås
- Ulospuhalluksen esto kielletty
- 排気口を塞がないで下さい。

(GB) The Piab Vacuum Pump has a 5 year warranty against manufacturing defects. The warranty is valid for the vacuum pump only and covers no other costs.

(DK) Piab vakuumpumper har 5 års garanti mod fabriktionsfejl. Garantien gælder kun vakuumpumperne, men ikke andre omkostninger eller fragtomkostninger.

(DE) Bei Herstellungsfehlern an der Piab Vakuumpumpe geben wir 5 Jahre Garantie. Verschleißteile wie z.B. Filter sind ausgeschlossen.

(ES) La bomba de vacío Piab tiene una garantía de 5 años contra defectos de fabricación. La garantía es válida para la bomba de vacío solamente sin cubrir gastos extras.

(FR) La pompe à vide Piab est garantie 5 ans contre les défauts de fabrication. La garantie est valable uniquement pour la pompe, et ne couvre pas d'autres frais, par exemple les frais d'expédition.

(IT) La pompa a vuoto Piab ha 5 anni di garanzia contro i difetti di fabbricazione. La garanzia è valida solo per la pompa a vuoto e non copre altri costi.

(NL) Piab vacuümpompen hebben een garantietermijn tegen fabricagefouten van 5 jaar. De garantie geldt alleen voor de pomp en dekt geen andere kosten.

(NO) Piab Vakuumpumper har 5 års garanti mot fabriktionsfeil. Garantien gjelder kun vakuumpumpen og dekker ikke andre kostnader eller fraktkostnader.

(PT) As bombas de vacuo Piab têm 5 anos de garantia contra defeitos de fabrico. A garantia é válida somente para as bombas de vacuo não cobrindo outros custos.

(SE) Piab Vakuumpump har 5 års garanti mot fabriktionsfel. Garantien omfattar enbart vakuumpumpen och täcker ej andra kostnader eller fraktkostnader.

(FI) Piab-tyhjöpumpuilla on 5-vuoden takuu koskien valmistusvirheitä. Takuu koskee ainoastaan tyhjöpumpua, eikä peitä muita kustannuksia taikka lähetyskuluja.

(日) ピアブのポンプには製造上の欠陥に限り五年間の保証があります。保証はポンプのみ有効です。

1. INSTALLATION/CONNECTION

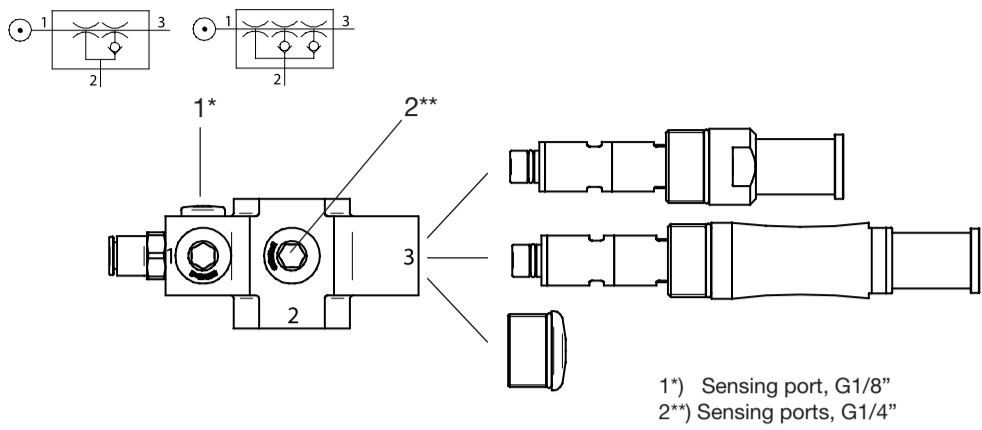

RECOMMENDED HOSE DIMENSIONS IN MM [IN.] (INTERNAL DIAMETER)

Connections		COAX® cartridge	
		Pi48-2, Pi48-3	Si32-2, Si32-3 / Xi40-2, Xi40-3
1.	Compressed air	≥ 6 [≥0.24]	≥ 4 [≥0.16]
2.	Vacuum	≥ 12 [≥0.47]	≥ 12 [≥0.47]
3.	Exhaust	≥ 15 [≥0.59]	≥ 15 [≥0.59]

FEED PRESSURE, VACUUM LEVEL AND EXHAUST

COAX® cartridge	Feed pressure MPa [psi]	Max. vacuum -kPa [-inHg]	Max. exhaust pressure MPa [psi]
Pi48-2, Pi48-3	0.30-0.60 [43.5-87]	90 [26.6] *	0.14 [20.3] **
Si32-2, Si32-3	0.60 [87]	75 [22.2]	0.08 [10.2]
Xi40-2, Xi40-3	0.45 [65]	95 [28.1]	0.09 [13.1]

2. MOUNTING

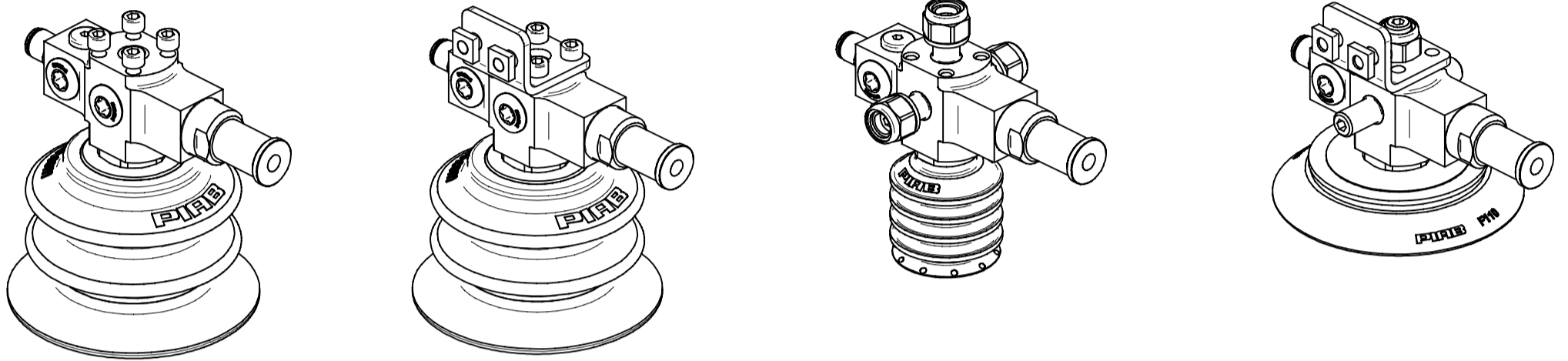

3. DIMENSIONS

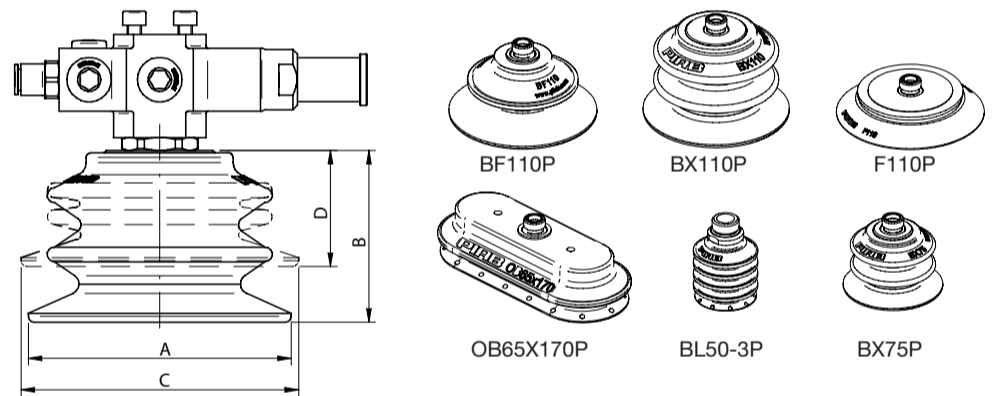
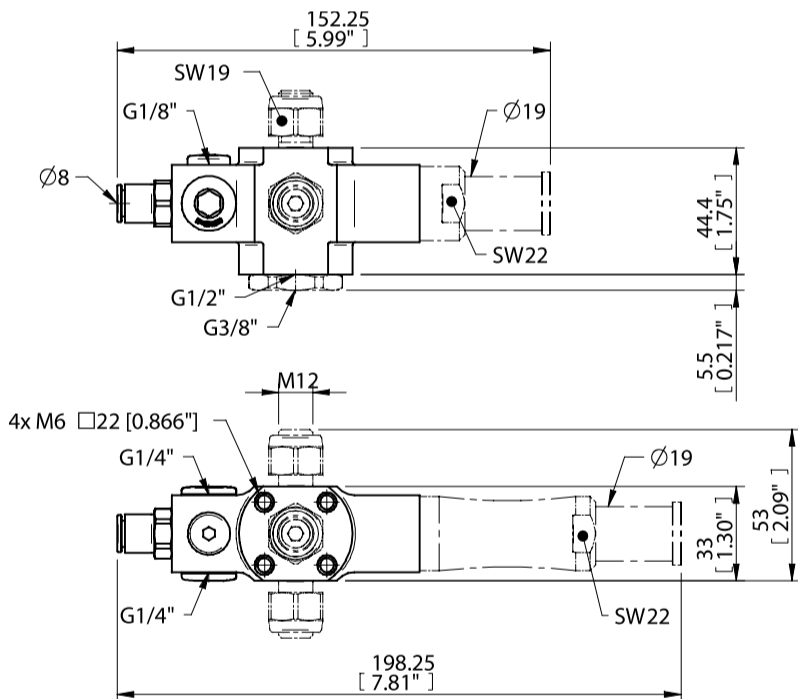

Model	Ø A mm [in]	B* mm [in]	Ø C mm [in]	D* mm [in]
BF110P	115 [4.53"]	53 [2.09"]	117 [4.61"]	29 [1.14"]
BL50-3P	48 [1.89"]	59 [2.32"]	49 [1.93"]	33 [1.30"]
BX110P	113.7 [4.48"]	74 [2.91"]	112.6 [4.43"]	35 [1.38"]
BX75P	77.5 [3.05"]	51.7 [2.04"]	77 [3.03"]	25.7 [1.01"]
F110P	115 [4.53"]	20.5 [0.81"]	119 [4.69"]	16.5 [0.65"]
OB 65x170P	72.2x177 [2.84"x6.97"]	41.5 [1.63"]	—	25.5 [1.00"]

* B-D Maximum vertical movement.

4. SPARE PARTS

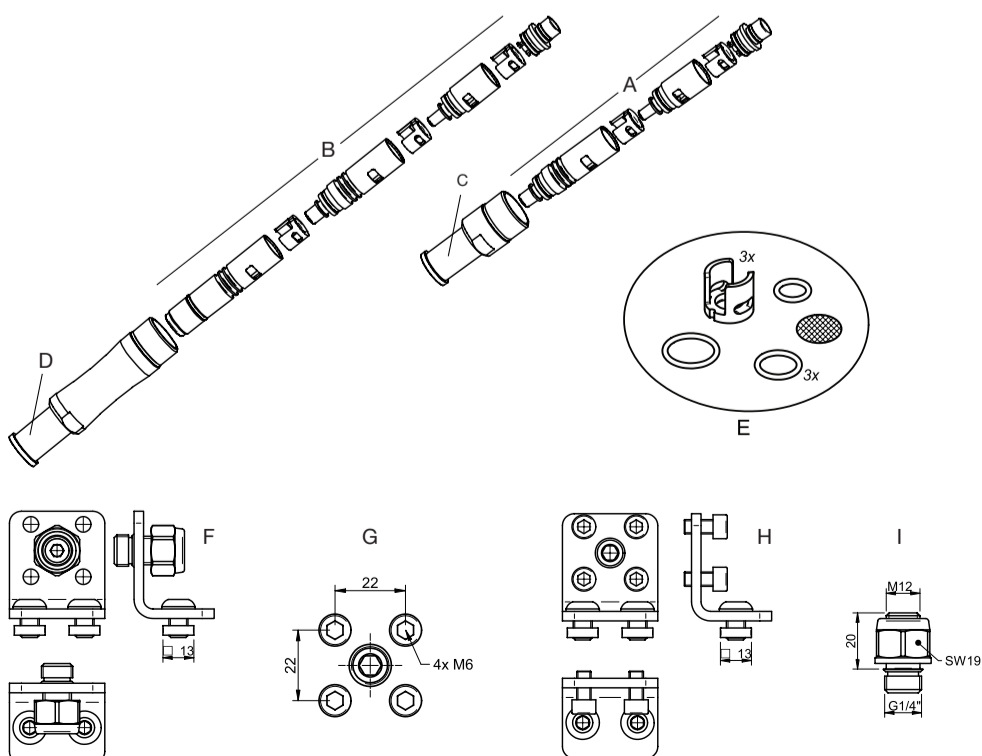

Description	Art. No.	
A	COAX® cartridge MIDI Pi48-2	0107125
A	COAX® cartridge MIDI Pi48-2, non-return valve	0107710
A	COAX® cartridge MIDI Si32-2	0107124
A	COAX® cartridge MIDI Si32-2, non-return valve	0107709
A	COAX® cartridge MIDI Xi40-2	0118747
A	COAX® cartridge MIDI Xi40-2, non-return valve	0118748
B	COAX® cartridge MIDI Pi48-3	0106639
B	COAX® cartridge MIDI Pi48-3, non-return valve	0107714
B	COAX® cartridge MIDI Si32-3	0107053
B	COAX® cartridge MIDI Si32-3, non-return valve	0107713
B	COAX® cartridge MIDI Xi40-3	0118724
B	COAX® cartridge MIDI Xi40-3, non-return valve	0118725
C	Cartridge holder MIDI 2 cpl.	0107130
D	Cartridge holder MIDI 3 cpl.	0107131
E	Spare part kit COAX® MIDI	0109531
F	Mounting kit M12/20, angle bracket	0114152
G	Mounting kit 4xM6, flush mount	0114162
H	Mounting kit 4xM6, angle bracket	0114163
I	Mounting kit M12/20	0114164