



# Operation Manual

Original Instructions

PRODUCT NAME

*Compact Compressor*

MODEL / Series / Product Number

CRP10-\*\*-\*\*-\*\*

**SMC Corporation**

# Contents

Safety Instructions	3
1. Outline	
1.1 How to order	9
1.2 Accessories	10
1.3 Compressor construction	11
1.4 Specifications	12
1.5 Parts description	13
1.6 Outline dimensions	15
2. Installation	
2.1 How to install the compressor	17
2.2 How to install the controller	18
3. Wiring and Piping	
3.1 Pressure switch setting	20
3.2 Wiring	22
3.3 Piping	23
4. Construction and parts	24
5. Alarm details and troubleshooting	25
6. Sample DoI	26



# Safety Instructions

These safety instructions are intended to prevent hazardous situations and/or equipment damage. These instructions indicate the level of potential hazard with the labels of “**Caution**,” “**Warning**” or “**Danger**.” They are all important notes for safety and must be followed in addition to International Standards (ISO/IEC)\*1), and other safety regulations.

\*1) ISO 4414: Pneumatic fluid power - General rules and safety requirements for systems and their components  
ISO 4413: Hydraulic fluid power - General rules and safety requirements for systems and their components  
IEC 60204-1: Safety of machinery - Electrical equipment of machines - Part 1: General requirements  
ISO 10218-1: Robots and robotic devices - Safety requirements for industrial robots - Part 1: Robots  
etc.



## **Danger**

**Danger** indicates a hazard with a high level of risk which, if not avoided, will result in death or serious injury.



## **Warning**

**Warning** indicates a hazard with a medium level of risk which, if not avoided, could result in death or serious injury.



## **Caution**

**Caution** indicates a hazard with a low level of risk which, if not avoided, could result in minor or moderate injury.



## **Warning**

### **1. The compatibility of the product is the responsibility of the person who designs the equipment or decides its specifications.**

Since the product specified here is used under various operating conditions, its compatibility with specific equipment must be decided by the person who designs the equipment or decides its specifications based on necessary analysis and test results. The expected performance and safety assurance of the equipment will be the responsibility of the person who has determined its compatibility with the product. This person should also continuously review all specifications of the product referring to its latest catalog information, with a view to giving due consideration to any possibility of equipment failure when configuring the equipment.

### **2. Only personnel with appropriate training should operate machinery and equipment.**

The product specified here may become unsafe if handled incorrectly. The assembly, operation and maintenance of machines or equipment including our products must be performed by an operator who is appropriately trained and experienced.

### **3. Do not service or attempt to remove product and machinery/equipment until safety is confirmed.**

1. The inspection and maintenance of machinery/equipment should only be performed after measures to prevent falling or runaway of the driven objects have been confirmed.
2. When the product is to be removed, confirm that the safety measures as mentioned above are implemented and the power from any appropriate source is cut, and read and understand the specific product precautions of all relevant products carefully.
3. Before machinery/equipment is restarted, take measures to prevent unexpected operation and malfunction.

### **4. Our products cannot be used beyond their specifications. Our products are not developed, designed, and manufactured to be used under the following conditions or environments. Use under such conditions or environments is not covered.**

1. Conditions and environments outside of the given specifications, or use outdoors or in a place exposed to direct sunlight.
2. Use for nuclear power, railways, aviation, space equipment, ships, vehicles, military application, equipment affecting human life, body, and property, fuel equipment, entertainment equipment, emergency shut-off circuits, press clutches, brake circuits, safety equipment, etc., and use for applications that do not conform to standard specifications such as catalogs and operation manuals.
3. Use for interlock circuits, except for use with double interlock such as installing a mechanical protection function in case of failure. Please periodically inspect the product to confirm that the product is operating properly.



# Safety Instructions

## Caution

**We develop, design, and manufacture our products to be used for automatic control equipment, and provide them for peaceful use in manufacturing business.**

**Use in non-manufacturing business is not covered.**

Products we manufacture and sell cannot be used for the purpose of transactions or certification specified in the Measurement Act.

The new Measurement Act prohibits use of any unit other than SI units in Japan.

## Limited warranty and Disclaimer/Compliance Requirements

The product used is subject to the following “Limited warranty and Disclaimer” and “Compliance Requirements”. Read and accept them before using the product.

### Limited warranty and Disclaimer

1. The warranty period of the product is 1 year in service or 1.5 years after the product is delivered, whichever is first.\*2)  
Also, the product may have specified durability, running distance or replacement parts. Please consult your nearest sales branch.
2. For any failure or damage reported within the warranty period which is clearly our responsibility, a replacement product or necessary parts will be provided.  
This limited warranty applies only to our product independently, and not to any other damage incurred due to the failure of the product.
3. Prior to using SMC products, please read and understand the warranty terms and disclaimers noted in the specified catalog for the particular products.

**\*2) Vacuum pads are excluded from this 1 year warranty.**

A vacuum pad is a consumable part, so it is warranted for a year after it is delivered.

Also, even within the warranty period, the wear of a product due to the use of the vacuum pad or failure due to the deterioration of rubber material are not covered by the limited warranty

### Compliance Requirements

1. The use of SMC products with production equipment for the manufacture of weapons of mass destruction (WMD) or any other weapon is strictly prohibited.
2. The exports of SMC products or technology from one country to another are governed by the relevant security laws and regulations of the countries involved in the transaction. Prior to the shipment of a SMC product to another country, assure that all local rules governing that export are known and followed.

## Design/Selection

### **Danger**

**1. Use this product only for general industrial applications.**

Do not use for any life-supporting applications such as respiratory equipment. Any damage to this product may result in a critical accident.

**2. Do not intake and compress fluid other than air.**

It could lead to fire or explosion.

**3. Do not install the product in an environment containing flammable gas, explosive gas, the organic solvents, explosive dust or corrosive gas.**

It may cause fire or explosion.

**4. This product (compressor and controller) does not have a waterproof structure.**

Do not use this product in an area where it could get wet, or in environments of high humidity and heavy condensation. This may cause an electric shock, earth leakage, or fire.

**5. Do not disassemble the product or make any modifications.**

It may cause human injury and/or an accident.

### **Warning**

The caution label shown below is attached to this product. Read and understand the warnings to ensure work safety.



The product becomes hot during operation. Touching it may cause burn injuries. In addition, residual heat after turning off the power may cause burn injuries. Avoid touching the product until it has cooled down sufficiently.



This product controls the pressure with the help of the pressure sensor and performs stopping and starting (unloading and loading) operations. During operation, avoid contacting the product.



Install and operate this product only after reading the Operation Manual carefully and understanding its contents.



The product contains a fan and parts that rotate at high speeds during operation. There is a risk of fingers or hand being cut or getting caught by rotating objects. Avoid touching the product during operation.

**1. Keep the manual in a safe place for future reference.**

The product should be mounted and operated only after thoroughly reading the operation manual and understanding its contents.

**2. When using this product in critical applications, make sure to provide a spare device or auxiliary equipment.**

This prevents damage when the operation is stopped due to failure or activation of the safety system.

**3. Do not install these products in corrosive gases such as ammonia, acids, salts, ozone gas, sulfurous gas, etc.**

It may cause rusting, reduced product life and damage.

**4. Overcurrent protection.**

Install a circuit breaker that complies with EN 60947-2 with a rated current of 6 A and B trip curve.

#### **5. Install an emergency stop air circuit.**

Install an emergency stop circuit in accordance with EN 60204-1 using an appropriate electrical disconnection device (complying with the required standards) to remove the electrical power and an appropriate device to vent the pneumatic pressure safely. Pay particular attention to the current rating of the disconnection device, the maximum trip current of the recommended 6A B-type circuit breaker is 30A. The pneumatic venting device should meet the required vent capacity appropriate to the system volume and required discharge time and be silenced to the required level.

#### **6. Consider emergency stops.**

Design so that human injury and/or damage to machinery and equipment will not be caused when machinery is stopped by a safety device under abnormal conditions, such as a power outage or a manual emergency stop.

#### **7. Consider the whole system.**

Design the system so that human injury or equipment damage will not occur upon the restart of operation of the whole system.

#### **8. To avoid inadvertent supply of electric power and compressed air while the equipment is stopped, install a device equipped with a locking functionality.**

#### **9. Make sure to connect the outlet of the PNP-type digital pressure switch to the PNP terminals on the controller. This product controls the pressure to unload / load by connecting the digital pressure switch to the controller.**

To ensure that the pressure does not exceed the specification range, set the pressure switch, and install a pressure regulating valve. Use of this product when pressure outside the operating range is applied may reduce the life or damage the product.

#### **10. Install a pressure switch separately.**

This product is not fitted with a pressure relief valve. Therefore, use a pressure switch of the required ISO 13849-1 performance level to operate the pneumatic venting device to the required Performance Level as selected from the risk assessment. (ref. ISO 12100 and ISO 13849-1)

## **Caution**

#### **1. Use the product in an area that is free of dust.**

Presence of dust may reduce life or cause product failure due to abnormal wear and other factors.

#### **2. Use the product at an ambient temperature between 5°C and 40°C during operation.**

Use of the product outside this temperature range may reduce life or cause product failure. In addition, the temperature protection system may activate to prevent motor burnout and stop the operation.

When using the product in close proximity to a heat source or in an enclosed storage space consider methods to cool and ventilate to maintain the ambient temperature at 40°C or less.

#### **3. Depending on the operating conditions, the surface temperature of the product may reach up to approx. 90 to 100°C and the discharged air temperature may be up to approx. 70°C. Confirm that the generated heat does not affect the surrounding.**

#### **4. Provide measures to treat the drain according to the use of compressed air.**

This product does not use any lubricating oil during the compression process. However, the compressed air generated contains a drain made of impurities such as moisture, oil content, dust, and wear particles from the atmosphere.

Make sure to consider methods of treating this drain as it may cause malfunction if it flows into pneumatic equipment such as cylinders.

#### **5. Select a power supply with sufficient capacity.**

The large inrush current at startup may affect devices connected to the same power supply.

## **Mounting**

## **Warning**

#### **1. Installation, inspection, or wiring should be conducted after the power supply to this product has been turned off.**

Electrical shock, malfunction, or damage can result.

#### **2. Before modifying or checking the wiring, the voltage should be checked with a tester 5 minutes after the power supply has been turned off.**

Failure to do so may result in electrical shock.

### 3. Maintenance space

Reserve sufficient space for maintenance and wiring.

### 4. Install the compressor body in an area with a solid surface and fasten it in place firmly.

Any displacement by vibration during operation may cause injury or product damage.

-The acceleration produced when the compressor is installed on a mounting frame with a weight of 1.9 kg and dimensions of 300 x 380 mm and then operated is 0.80 G (reference value).

-The acceleration produced when the compressor is installed on a mounting frame with a weight of 9.4 kg and dimensions of 500 x 700 mm and then operated is 0.21 G (reference value).

### 5. Do not carry the product by holding its cables.

It may cause an injury or damage to the product.

### 6. Shade the product from direct sunlight.

### 7. If the vibration transferred to the embedded structure deemed large, provide appropriate vibration-proof treatment when fastening the product.

Vibration may transfer to the structure and increase the noise level.



## Caution

### 1. This product exhausts heat using an axial flow fan. Make sure the suction and exhaust grill are unobstructed when installing the product.

The temperature protection system will activate if the motor overheats and stop the operation.

### 2. Install the controller and its peripheral devices on a flat surface.

If the mounting surface is distorted or uneven, an unacceptable force may be added to the housing, etc., causing problems.

## Wiring



## Warning

### 1. Do not connect wires while power is being supplied.

It may cause the controller to break or its peripheral devices could be damaged, causing a malfunction.

### 2. Before wiring, check that the power supply has sufficient capacity and that the voltage is at the specified value.

### 3. Never disassemble the cable. Use only the specified cables.

### 4. Never connect or disconnect the cable or connector with the power on.

### 5. Do not perform the operation or setting of the product with wet hands.

Doing so may cause an electric shock.

### 6. Operate with cables such that they are not easily moved.

Avoid contact with this compressor.

### 7. Avoid twisting, folding, rotating, or applying external force to the cable.

Electric shock, wire breakage, contact failure, or a loss of product control may occur.

### 8. In case of power supply has overcurrent protection function, Automatic recovery type and Constant current type are adequate.



## Caution

### 1. When plugging or unplugging the cable connector, release the detachment prevention mechanism while manually supporting the plug. Connect or disconnect the connector in the same direction as the connector pin to prevent the application of excessive force.

It may cause malfunctions.

### 2. Wiring should be done correctly. For each terminal, voltages other than those stipulated in the operation manual should not be applied.

### 3. Connect the connector securely.

Check for correct connector wiring and polarity.

### 4. Be sure to carry out grounding in order to ensure the noise tolerance.

The ground points should be near the compressor or the controller to make the wire length shorter.

## Piping

### **Warning**

- 1. Start-up of this product may be unstable or disabled while it is still pressurized.**  
Release the pressure inside before restarting the product.
- 2. Make sure to mount a silencer to the inlet port.**  
This will reduce the noise and prevent intrusion of any foreign matter.
- 3. Use piping materials that can accept the rise in temperature that can result from use of this product.**

## Handling

### **Warning**

- 1. If a danger of human injury is expected due to abnormal heat generation, smoking, ignition, etc., of the controller and its peripheral devices, cut off the power supply of the product and the system immediately.**
- 2. Do not operate in series or apply pressure to the inlet port.**  
The discharge pressure will exceed the specifications and may cause damage or accidents.
- 3. When using in an environment with high humidity, regularly perform flushing and discharge the condensed water to prevent accumulation of condensed water inside the product.**  
Otherwise, the performance will significantly deteriorate.

#### **[Storage]**

- 1. Do not store the product in a place in direct contact with rain or water drops or where it is exposed to harmful gas or liquid.**
- 2. Store in an area that is shaded from direct sunlight and has a temperature and humidity within the specified range (10°C to 30°C and 35 to 85% no condensation or freezing).**
- 3. Do not apply vibration or impact to the product during storage.**

#### **[Disposal]**

The disposal of the product must be handled by a specialized industrial waste disposal agency in accordance with the relevant local laws and regulations.

### **Caution**

- 1. Do not switch the suction and exhaust ports to change from a positive pressure (compressor) application to a negative pressure (vacuum pump) application.**  
The performance will be significantly reduced. This warning also applies in the opposite situation.
- 2. Do not use this product at an altitude of 1000 m or higher.**  
The product's performance will be degraded due to the decrease in air density.
- 3. This product cannot be disassembled. Therefore, when it needs to be repaired, contact your distributor.**

#### **[Compliance]**

##### **(1) EMC Directive/Regulations**

This product conforms to the applicable CE/UKCA EMC Directive/Regulations as stated on the Declaration of Conformity when used on its own in accordance with the instructions.

When installed in the finished machine, the conformity with the applicable CE/UKCA EMC Directive/Regulations shall be confirmed before putting into service.

##### **(2) Machinery Directive/Regulations**

This product is partly completed machinery under the CE/UKCA Machinery Directive/Regulations and has been supplied with a Declaration of Incorporation.

When installed in the finished machine, the conformity with the applicable essential health and safety requirements of the CE/UKCA Machinery Directive/Regulations shall be confirmed.



# 1.Outline

## 1.1 How to order

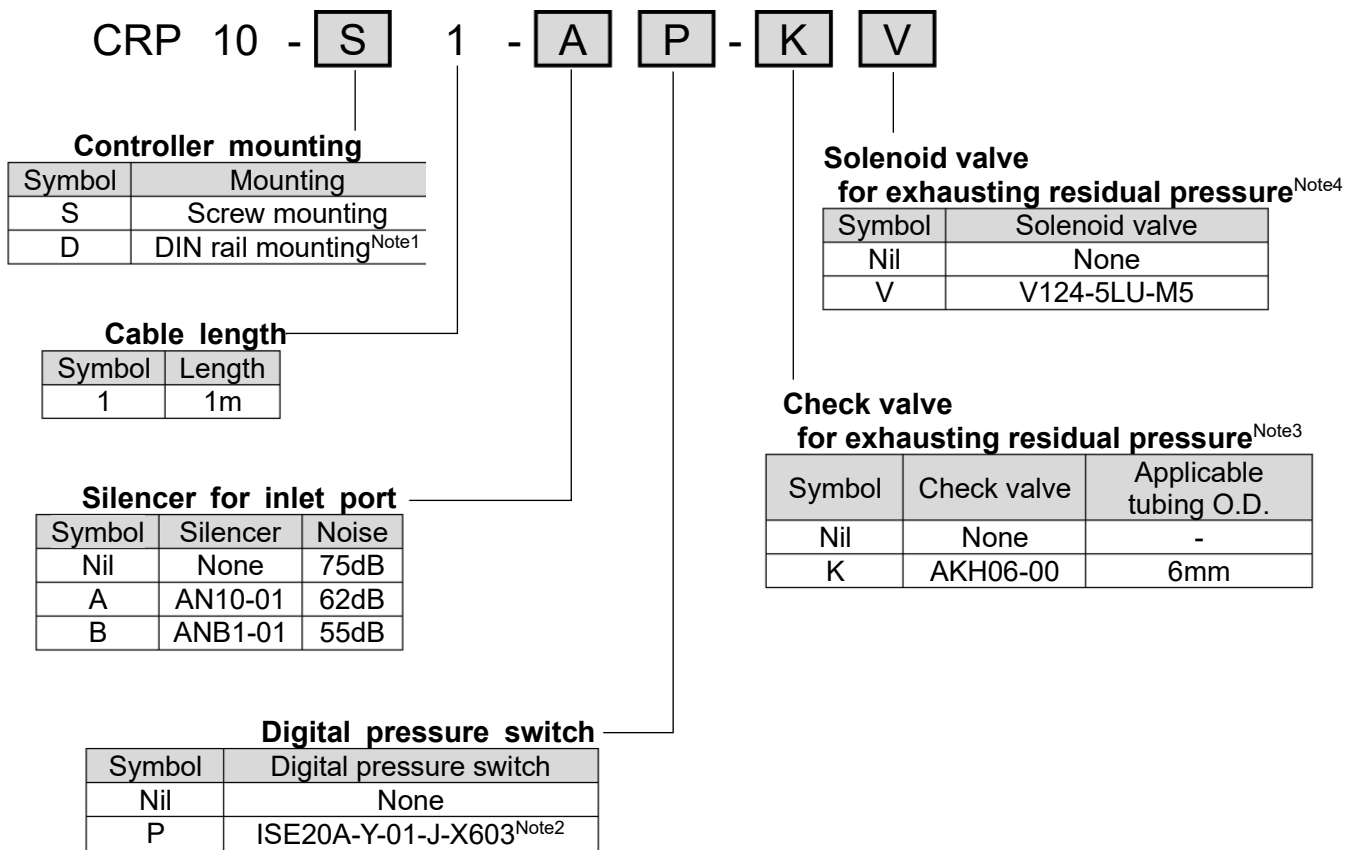

Note1) DIN rail mounting bracket is included in the package. DIN rail is not supplied.

Note2) Items below are set as the default setting for ISE20A-Y-01-J-X603.

- Reversed output setting; Reversed output
- Pressure setting; n\_1, n\_2=0.3(MPa)
- Hysteresis; H\_1, H\_2=0.2(MPa)

Order separately for piping specifications other than M5 and for options.

Note3) AKH06-00, which is the check valve with One-touch fittings (straight type) is selected.

A separate order is necessary when selecting different piping diameters, male connector types, and other specifications.

Note4) It is of a direct operated 3-port solenoid valve V100 series and the normally open specification.

In addition, the read wire length of the connector assembly is 300 mm and a silencer AN05-M5 for the exhaust port is included in the package.

Select the direct operated type when using other solenoid valves.



This product controls pressure by connecting the pressure switch to the controller and performs stop and startup (unload/load).  
Select a PNP output specification when ordering separately.



Configure a residual pressure relief circuit. See section 23, piping.  
It does not start up or restart when pressure is remaining in the compressor.

## 1.2 Accessories

### 1) Controller



### 2) DIN rail mounting bracket (P/N P604010-1)

Provided when D is selected for the controller mounting method.



Longer hooks



Cross recessed binding head screw; 4pcs  
M3x0.5x6



Longer hooks

### 3) Motor cable 1m



### 4) Sensor cable 1m



### 1.3 Compressor construction

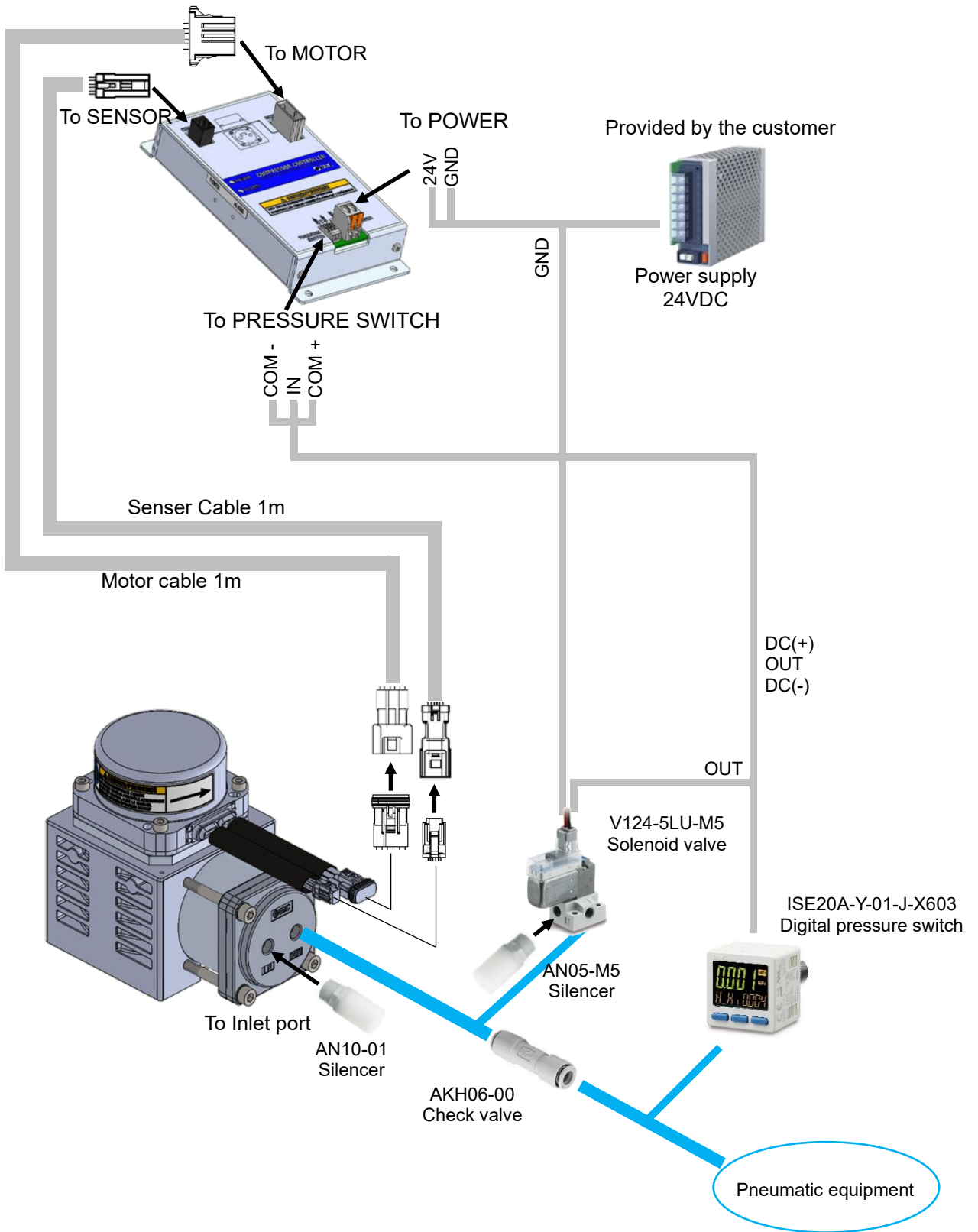

 Refer to the catalog and operation manual of the individual components when using them.

## 1.4 Specifications

Items		Specifications	
Compressor	Compression method	Reciprocating (oil-free)	
	Max. discharge/ vacuum pressure	0.55MPa/ -70kPa	
	Max. discharge/ vacuum flow rate	10L/min (ANR)	
	Pressure ratio	6.5	
	Motor speed	1500min <sup>-1</sup>	
	Unloader method	Digital pressure switch	
	Duty cycle	Continuous	
	Noise <sup>Note1</sup>	AN10-01: 62dB or less ANB1-01: 55dB or less	
	Sound pressure level <sup>Note2</sup>	AN10-01: 63dB or less ANB1-01: 62dB or less	
	Sound power level <sup>Note2</sup>	AN10-01: 74dB or less ANB1-01: 73dB or less	
	Operating temperature range	5 to 40°C	
	Operating humidity range	80%RH or less (No condensation)	
	Weight	3.1kg	
Controller	Installation	Separation	
	Power supply	DC24V±10% <sup>Note3</sup>	
	Rated current	4.5A	
	Instantaneous current consumption	Max. 8A <sup>Note4</sup>	
	LED display	Function	status
		POWER (green)	Power ON: Light
		ALARM (red)	Alarm: Light or flashing
	Pressure switch input	IN (Input for Pressure switch) 1 PNP input Input current 3.5mA±20% at DC24V	
		COM+, COM- (Power supply output for Pressure switch) DC24V+10%-15%, Max. supply current 200mA	
	Pressure switch compatible part number	High-Precision Digital Pressure Switch ISE20 series, PNP open collector output type ISE20A-Y-***-J-X603	
	Mounting	Screw mounting / DIN-rail mounting	
	Cable length	1m or less	
	Cooling system	Natural air cooling	
	Operating temperature range	5 to 40°C	
	Operating humidity range	80%RH or less (No condensation)	
Insulation resistance	Between batch of external terminals and case 50MΩ (DC500V)		
Weight	Screw mounting 340g		
	DIN rail mounting 360g		

Note1) Reference values based on a position 1 m away from the intake port in an anechoic chamber at positive pressure.

Note2) Reference values in according to ISO 2151

Note3) In case of power supply has overcurrent protection function, Automatic recovery type and Constant current type are adequate.

Note4) The inrush current varies with the capacity of the power supply.

The duration is not normally long enough to operate the circuit breaker (6A B-type).

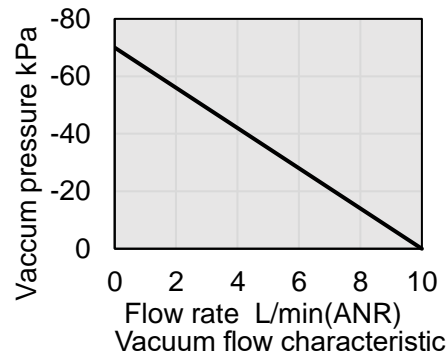
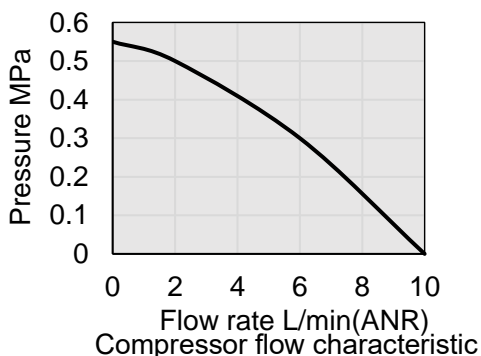

## 1.5 Parts description

The detailed descriptions of each part of the compressor are follows:

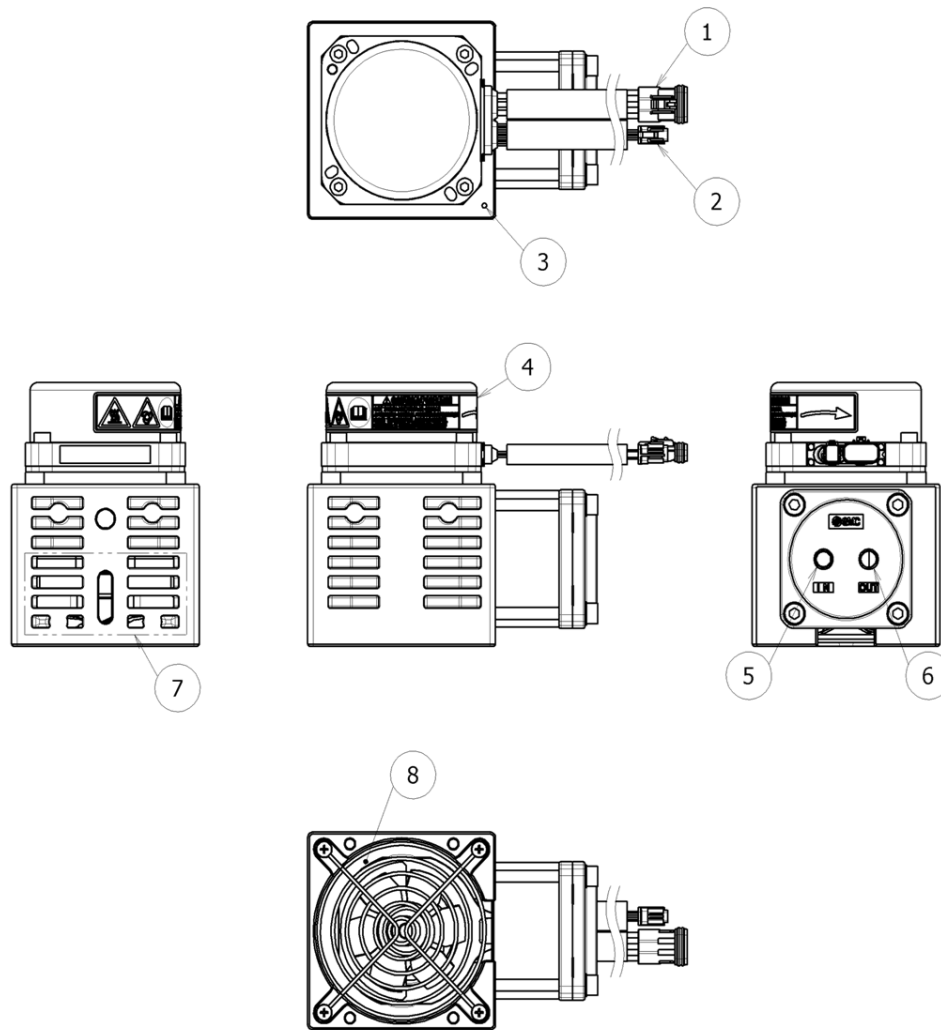

No.	Name	Description
1	Motor power connector (3 pins)	Use to connect motor cable.
2	Motor sensor connector (6 pins)	Use to connect sensor cable.
3	FE	Function earth Use to connect the earth wire.
4	Caution label	Do not remove the caution label under any circumstance.
5	Inlet port	When using the product as a compressor, mount the silencer AN10-01 or ANB1-01 here (supplied as an accessory).
6	Discharge port	When using the product as a vacuum pump, mount the silencer AN10-01 here (supplied as an accessory).
7	Air intake	 An axial flow fan exhausts heat through the vent. Be aware that when the vent is blocked, the product can overheat, and operation will be stopped by a safety function.
8	Heat vent	

The detailed descriptions of each part of the controller are follows:

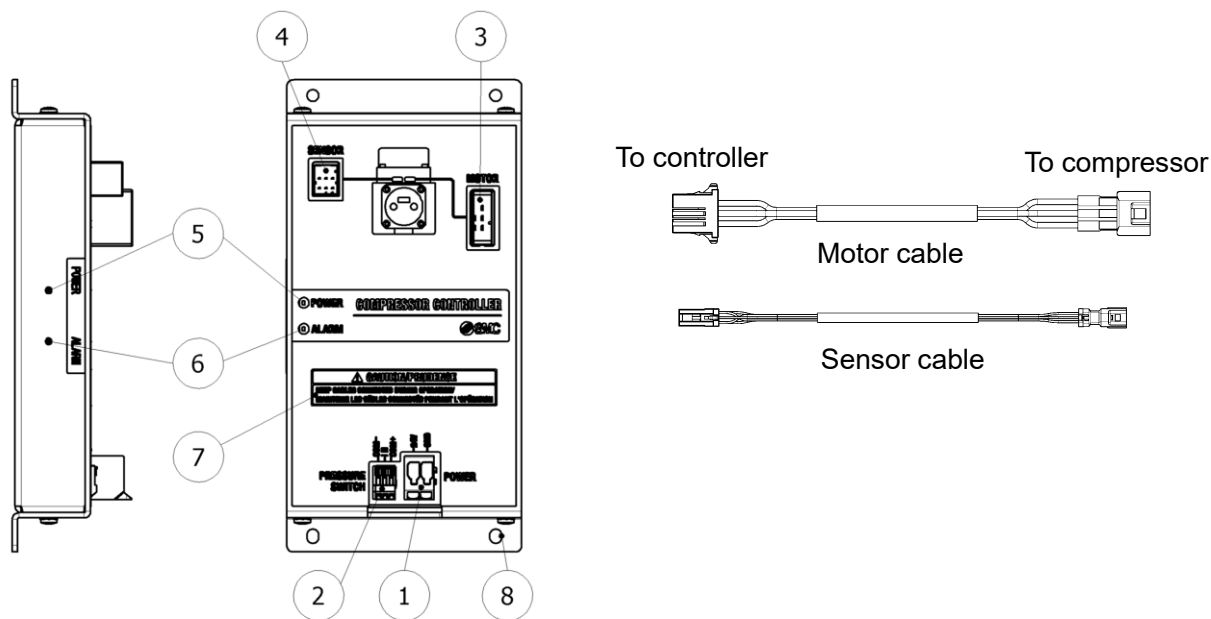

No.	Label	Name	Description
1	POWER	Power supply connector (2 pins)	Use to connect the controller power supply (DC24V). 24V: Connect to the 24 VDC of the power supply GND: Connect to the 0 VDC of the power supply
2	PRESSUER SWITCH	Pressure switch connector (3 pins)	Connect the output of the pressure switch and the power supply input. <b>IN:</b> Connect to the output of the pressure switch. <b>COM+:</b> Connect to the + side of the power supply input of the pressure switch. <b>COM-:</b> Connect to the + side of the power supply input of the pressure switch.
<p>The diagram shows the internal circuit for the pressure switch connector. It features three external pins: COM+, IN, and COM-. COM+ is connected to a 24V output. IN is connected to a 6.8kΩ resistor, which is in series with a 1.0kΩ resistor connected to the IN pin of a relay. COM- is connected to a 0V output.</p>			
3	MOTOR	Motor power connector for compressor (3 pins)	Use to connect the motor cable.
4	SENSOR	Motor sensor connector for compressor (6 pins)	Use to connect the sensor cable.
5	POWER LED	Power supply LED (green)	Power ON: Green light
6	ALARM LED	Alarm LED (red)	Alarm: Red light or flashing
7	Caution	Caution label	Do not remove the caution label under any circumstance.
8	-	FE	Functional earth Fasten it with the controller mounting screw when mounting the controller and connect the grounding cable. See page 17.

## 1.6 Outline dimensions

The dimensions of the compressor are shown in the diagram below.

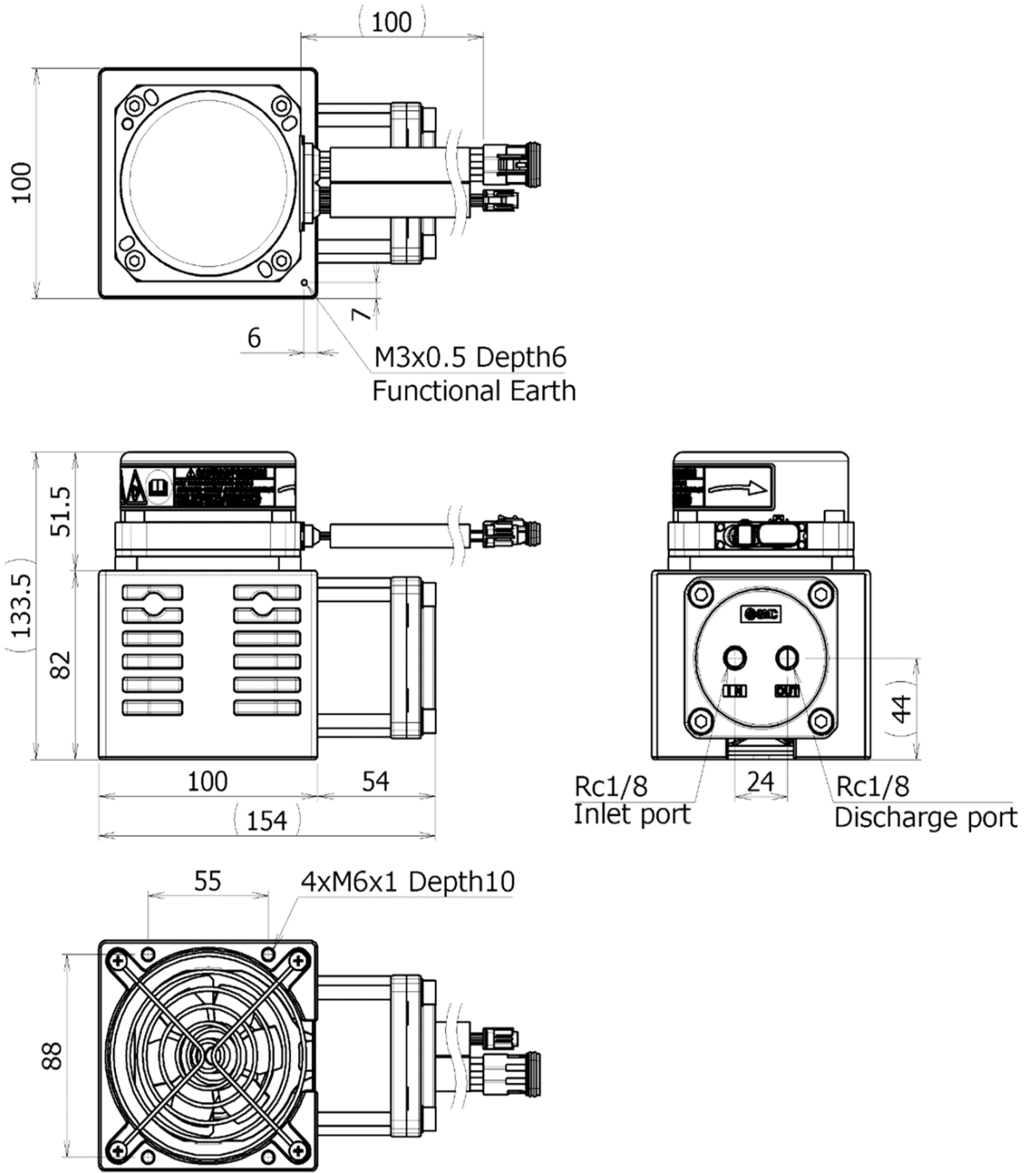

The dimensions of the controller are shown in the diagram below.

1) Screw mounting

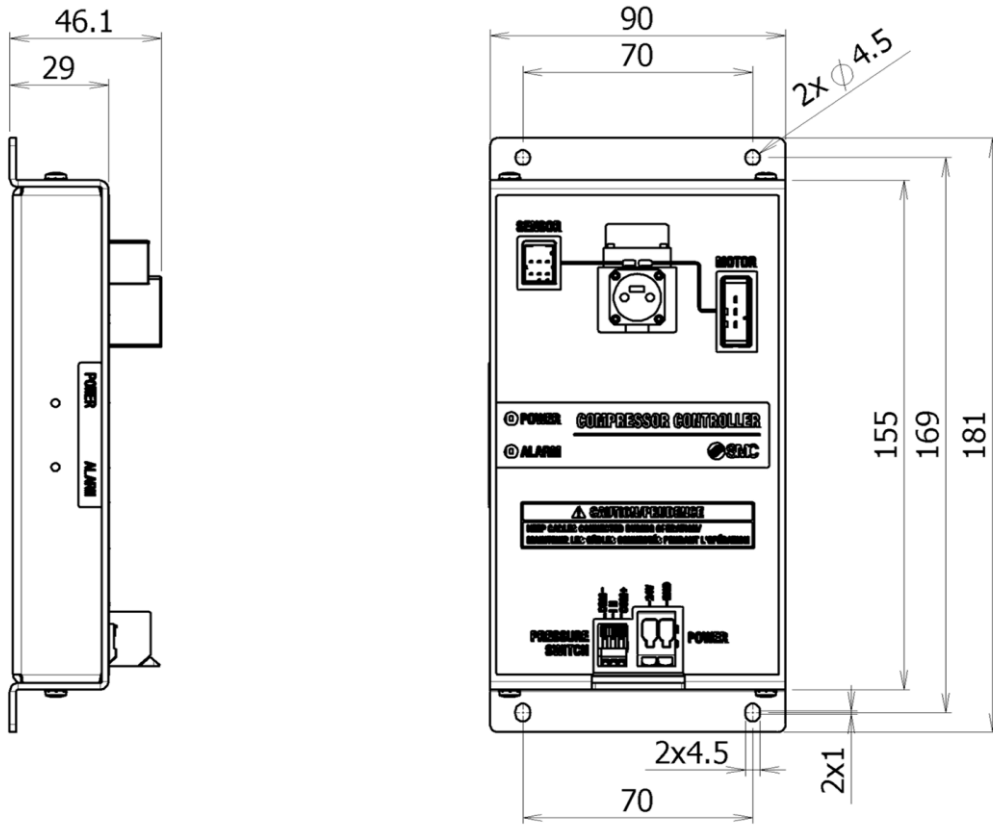

2) DIN rail mounting

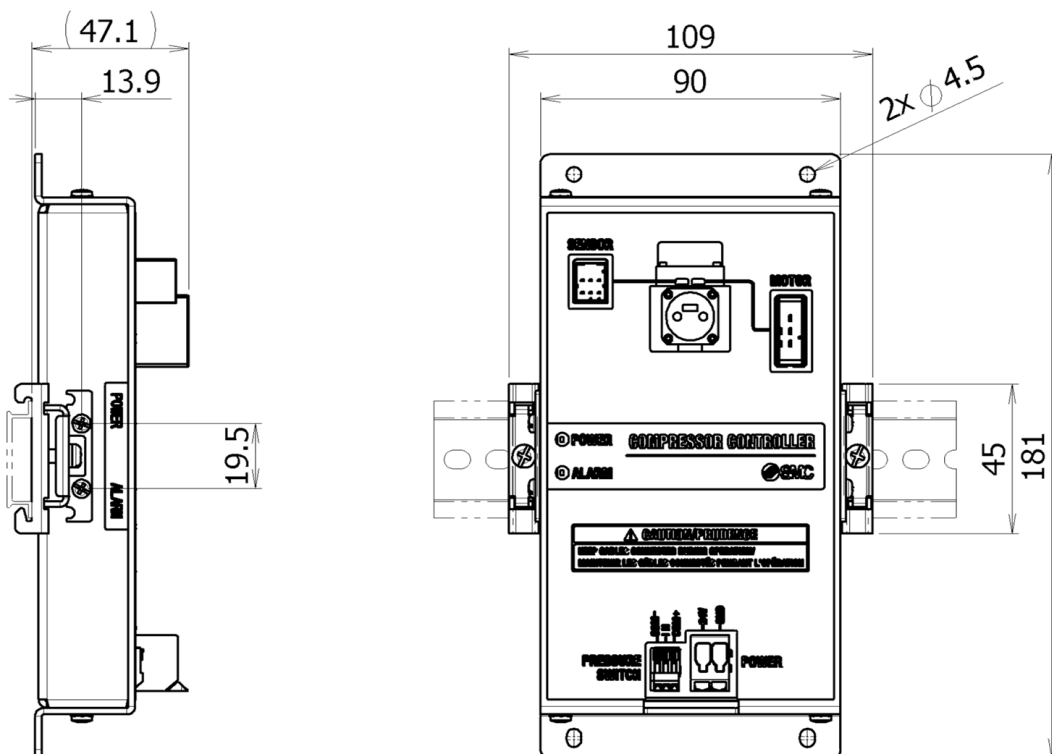



## 2. Installation

### 2.1 How to install the compressor

#### 1) Installing the compressor

Air intake and heat exhaust functions use a fan to cool down the compressor. Ensure a clearance of 30mm or more from the installation surface, 30mm or more around the product, and enough space for maintenance.

Use M6x1 stud bolts and M6 nuts for fastening the product to the installation surface. Use anti-vibration rubber if a large amount of vibrations are transferred to the embedded surface.

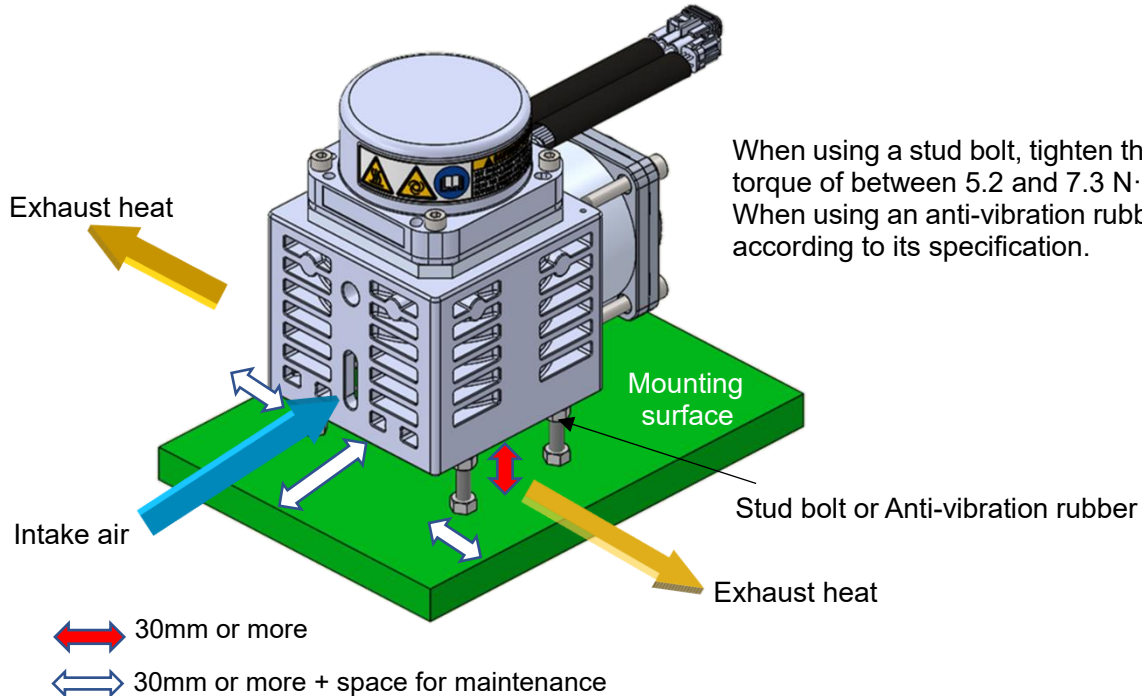

#### 2) Ground wire connection

Connect the grounding cable to the compressor to shield the brushless motor from noise.  
Use M3 x 0.5 screws.

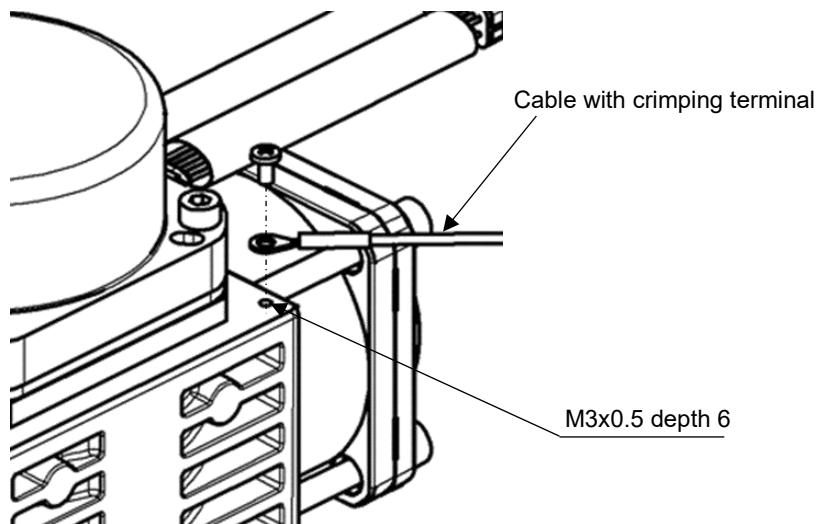

### **⚠ Caution**

The M6 stud bolts, M6 Nuts, or the anti-vibration rubber, and the cable with crimping terminal, M3 screw should be obtained separately.  
Ground the compressor to shield it from electric noise.

## 2.2 How to install the controller

### 1) How to install

The controller can be direct mounted using screws or mounted on a DIN rail.  
The followings are the descriptions on how to install each type.

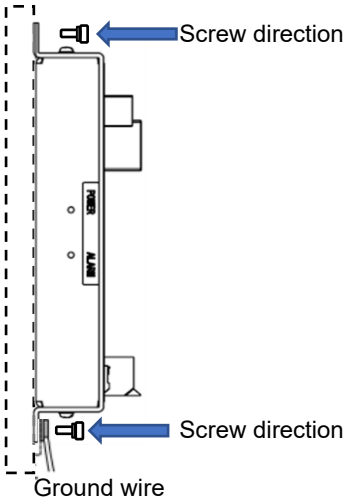
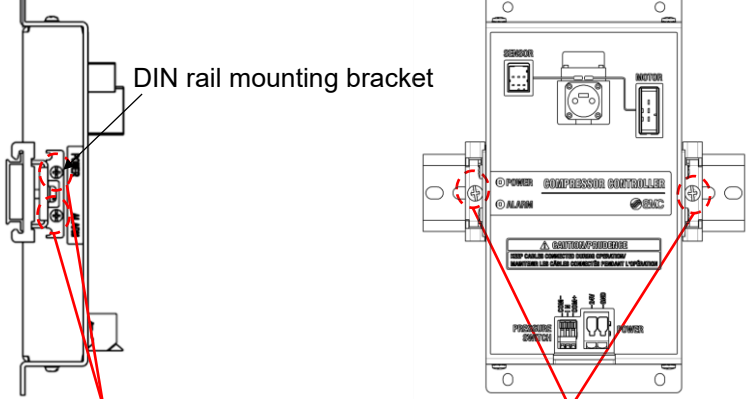
1) Screw mounting	2) DIN rail mounting
Installation with four M4 screws	Installation with the DIN rail
	 <p data-bbox="646 761 981 884">Mount the DIN rail brackets the controller using M3x6 screws supplied with the product (use tightening torque of 0.4N·m).</p> <p data-bbox="1045 761 1444 907">Mount the controller onto the DIN rail plates using M4 screws supplied with the DIN rail mounting brackets. (use tightening torque of 0.6N·m).</p>

### 2) Ground wire connection

Connect the grounding cable with any of the screws used in mounting the controller to any of the four screw holes of the controller. Note that M4 nuts need to be obtained separately when using the DIN rail mounting. See below for examples of both mounting types.

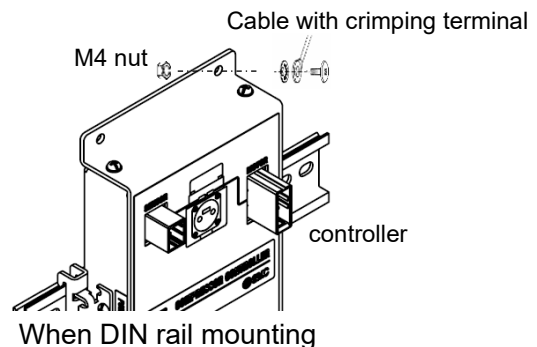
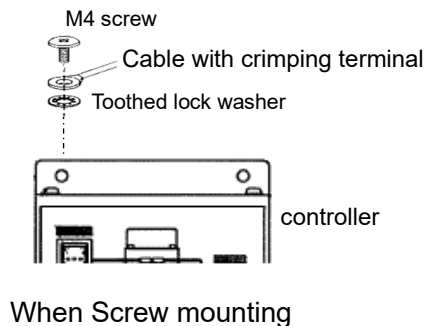

### ⚠ Caution

The M4 screw, cable with crimping terminal, toothed lock washer, M4 nut should be obtained separately. Ground the controller to shield it from electric noise.

### ⚠ Caution

The earthing should be the dedicated grounding point for function grounding.  
The cross section of the grounding wire should be greater than 2mm<sup>2</sup>.  
The ground point should be near this controller to make the wire length shorter.

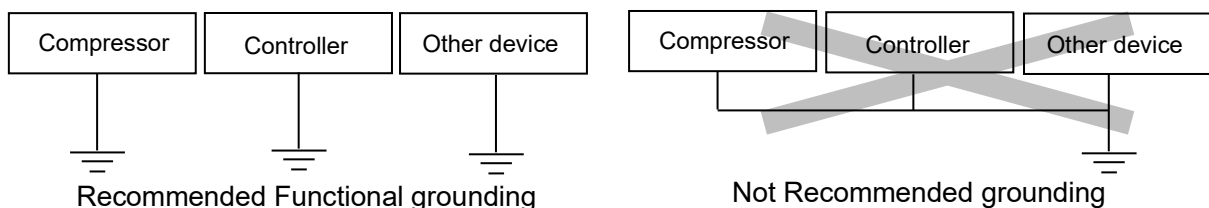

### 3) Mounting location

Design the size of the control panel and the installation so that the temperature surrounding the controller is 5 to 40°C or less. Allow 60 mm minimum space between the front of the controller and the door (lid) so that the connectors can be connected and disconnected as shown below.

Avoid mounting the controller near a vibration source, such as a large electromagnetic contactor or circuit breaker on the same panel.

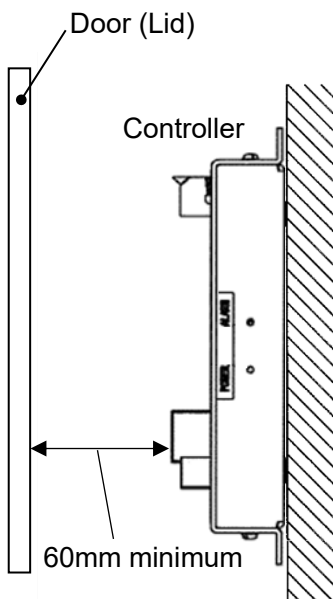

### Caution

If the mounting surface for the controller is not flat or is uneven, excessive stress may be applied to the enclosure, which can cause failure. Be sure to mount on a flat surface.

### 3. Wiring and Piping

#### 3.1 Pressure switch setting

This product controls the pressure and performs stop / start (unload / load) by connecting the pressure switch to the controller. Use the designed setting when transmitting the output of the pressure switch to PLC and receiving from the PLC to the controller.

Recommended pressure switch product number: ISE20A-Y-\*-J-X603

1) Supply 24 VDC power source to the controller and the pressure switch. At this time, do not connect to IN.

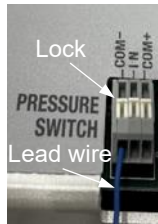
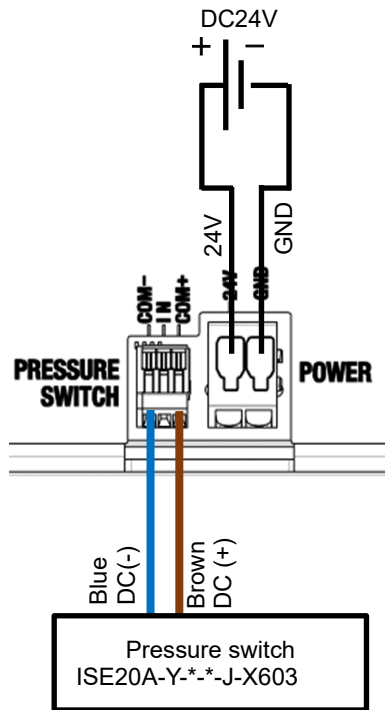

Insert the lead wire.  
The lead wire is not secured when the white lock is down.

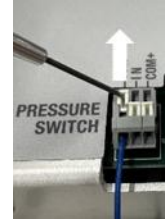

Use a tool, such as a watchmaker's screwdriver to lock by pushing upwards.

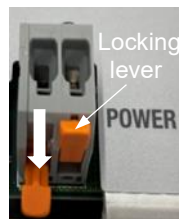

Push down the locking lever to unlock.



Insert the lead wire and return the lever to its locked position.

Connect the blue lead wire [DC (-)] of the pressure switch to the controller [COM-].  
Connect the brown lead wire [DC (+)] of the pressure switch to the controller [COM+].

#### Caution

In case of power supply has overcurrent protection function, Automatic recovery type and Constant current type are adequate.

Reverse connection of supply power voltage may result in a malfunction.

- 2) Operate the pressure switch and configure it to the settings similar to the example below.  
Refer to the ISE20 series, catalog, and Operation Manual for information on how to configure.

Example of positive pressure

Load pressure = 0.3MPa, Unload pressure = 0.5MPa:

- Output mode: Hysteresis mode
- Normal or reversed output: Reversed output
- Set pressure value (Threshold value): n\_1, n\_2=0.3 (Load pressure)
- Hysteresis value: H\_1, H\_2=0.2 (Unload pressure - Load pressure)
- Delay time: Optional
- Display color: Optional

Function	Content	Setting	Value
F1	Reversed output setting	1ot	1_n (Reversed output)
	Pressure setting	n_1	0.300(MPa)
	Hysteresis setting	H_1	0.200(MPa)
F2	Reversed output setting	2ot	2_n (Reversed output)
	Pressure setting	n_2	0.300(MPa)
	Hysteresis setting	H_2	0.200(MPa)

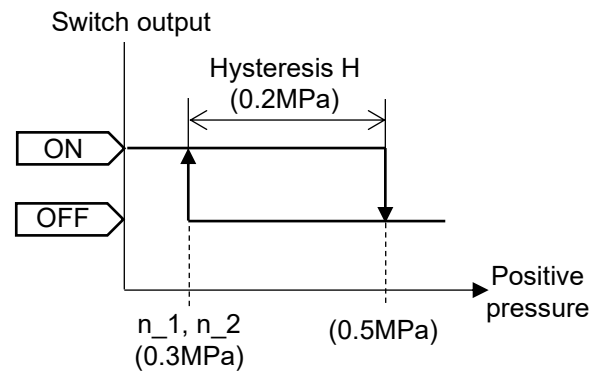

Refer to the operation manual PS\*\*-OMU0003.

The ISE20A-Y-01-J-X603 digital pressure switch has the reverse output and pressure setting in the above example as default.

Example of negative pressure:

Load pressure = -50kPa (-0.050MPa), Unload pressure = -70kPa (-0.070MPa):

- Display unit selection: kPa or MPa
- Output mode: Hysteresis mode
- Normal or reversed output: Normal output
- Set pressure value (Threshold value): P\_1= -50kPa (0.05MPa) (Load pressure), n\_2= -70kPa (0.07MPa) (Unload pressure)
- Hysteresis value: H\_1, H\_2=20kPa ( |Unload pressure - Load pressure| )
- Delay time: Optional
- Display color: Optional

Function	Content	Setting	Value	
F0	Display unit selection	Unit	kPa	MPa
F1 For compressor	Reversed output setting	1ot	1_P (Normal output)	
	Pressure setting	P_1	-50(kPa)	-.050(MPa)
	Hysteresis setting	H_1	20(kPa)	0.020(MPa)
F2 For solenoid valve	Reversed output setting	2ot	2_n (Reversed output)	
	Pressure setting	n_2	-70(kPa)	-.070(MPa)
	Hysteresis setting	H_2	20(kPa)	0.020(MPa)

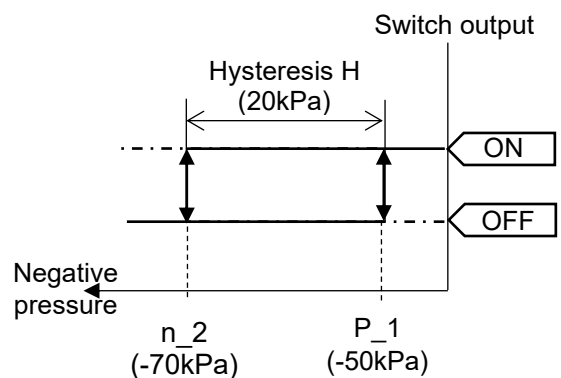

### 3.2 Wiring

The diagrams below show the connections of the compressor and the controller.

1) Connect the compressor.

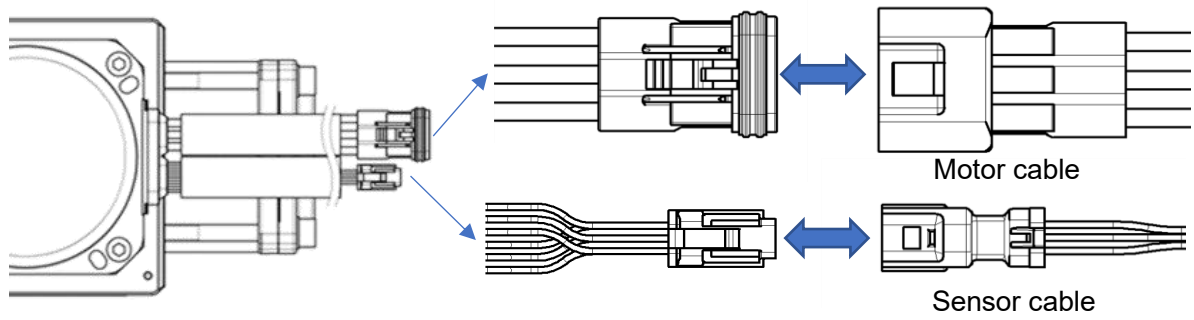

2) Connect the controller.

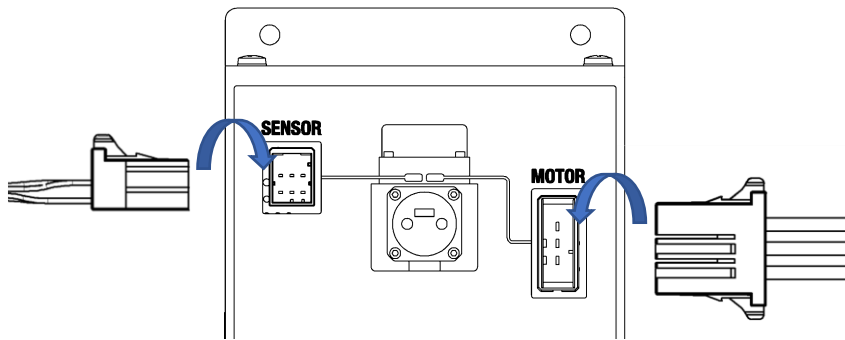

3) Connect the pressure switch. A wiring example with a solenoid valve is shown below.

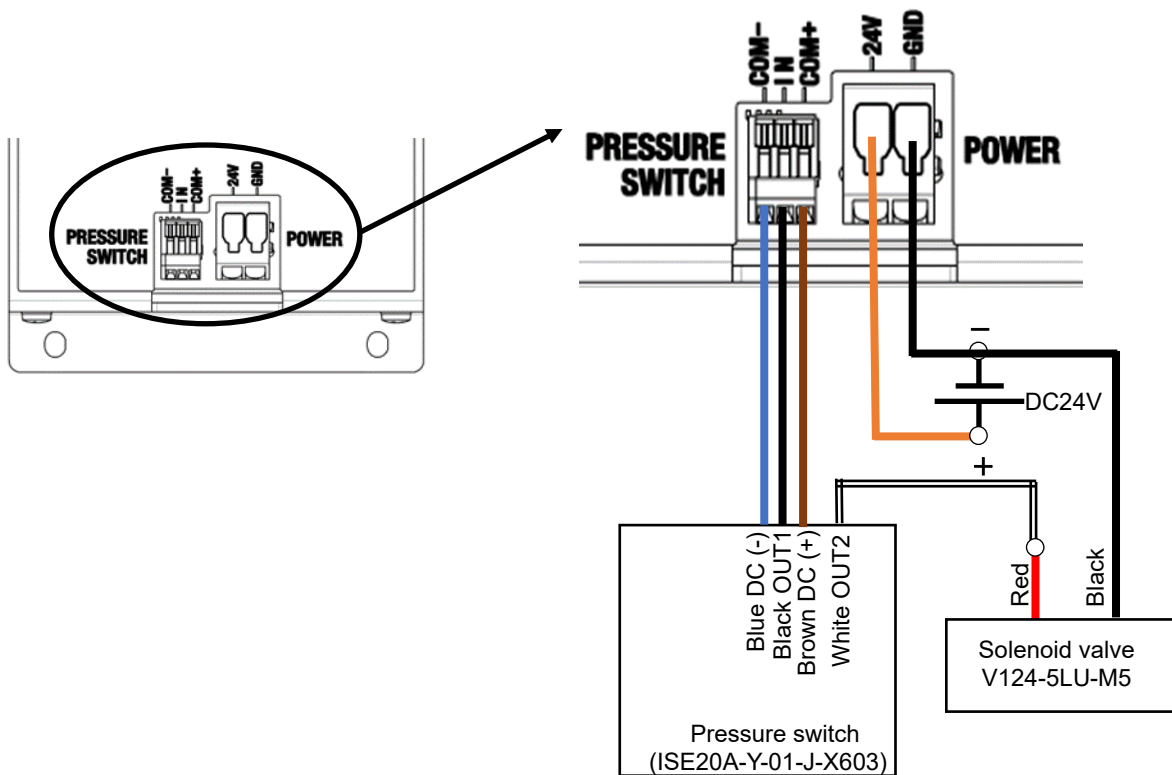

### 3.3 Piping

Attempting to start the product with any pressure inside may cause the start-up to be unstable or disabled. To avoid this, prepare the pneumatic circuit to allow the exhaust of any residual pressure into the atmosphere before restarting the product. The diagrams below provide an example pneumatic circuit to be used in conjunction with the wiring diagram from 3.2.

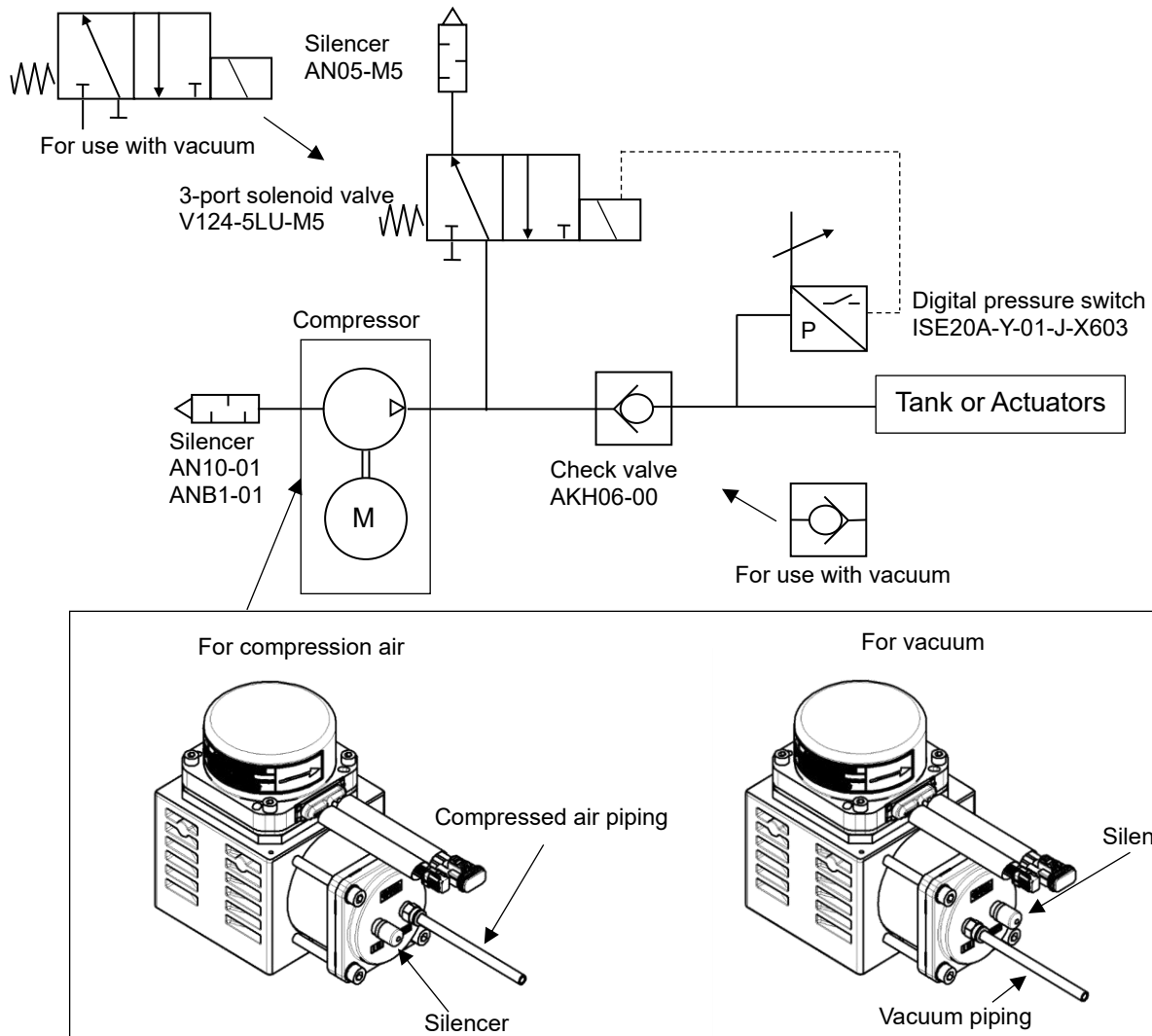

See the catalog and operation manual of the ISE20 series for piping, mounting, and details of other option parts for the digital pressure switch ISE20A-Y-01-J-X603.

### **! Caution**

Configure the circuit described above when internal pressure of the compressor is below atmospheric pressure even under vacuum.

Make sure to mount a silencer. This will reduce noise and prevent the intrusion of any foreign matter.

## 4. Construction and parts

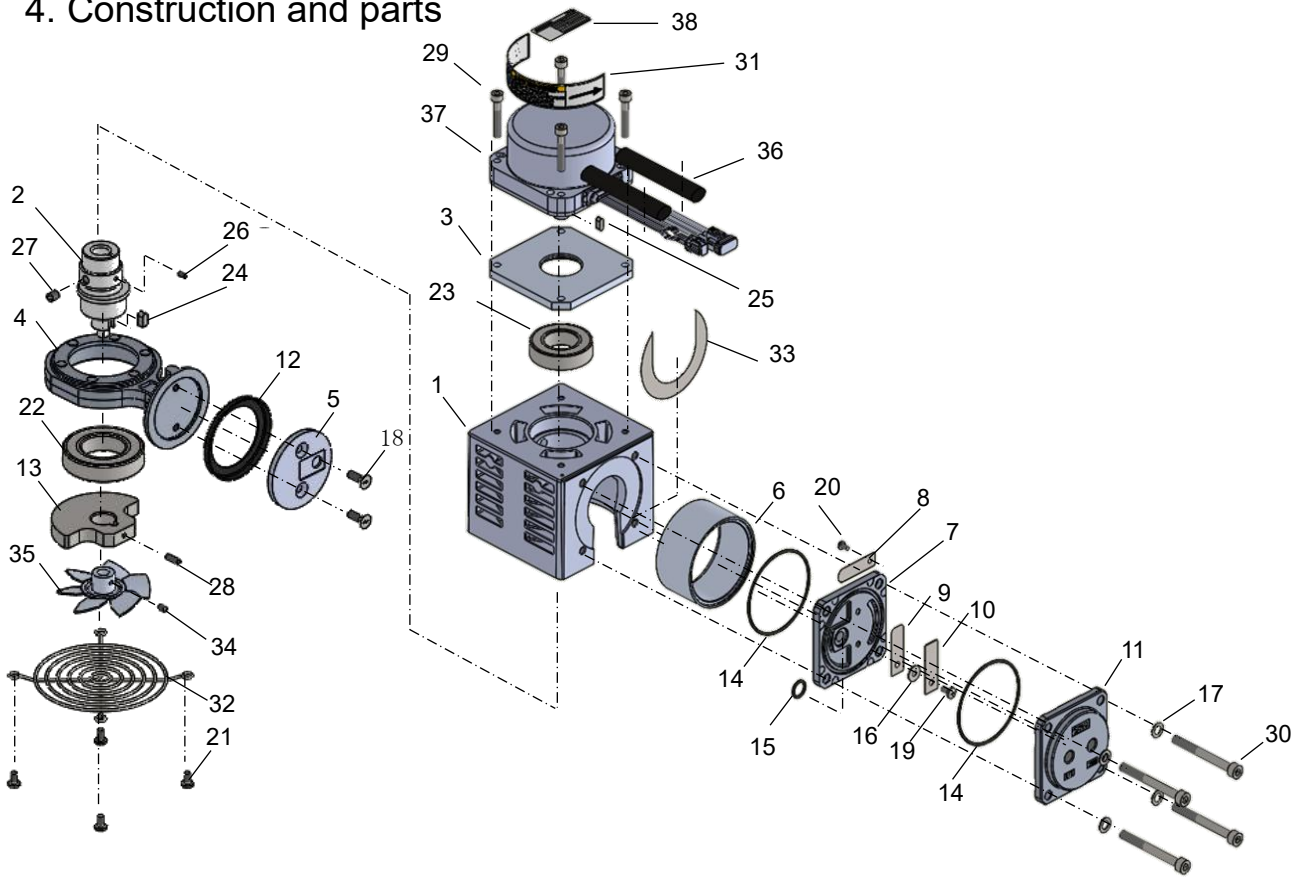

20	Cross recessed binding head screw	Stainless steel	1
19	Cross recessed binding head screw	Stainless steel	1
18	Cross recessed countersunk head screw	Stainless steel	2
17	Plain washer	Steel wire	4
16	Plain washer	Stainless steel	1
15	O-ring	HNBR	1
14	O-ring	HNBR	2
13	Counter weight	Carbon steel	1
12	Piston ring	PTFE	1
11	Head cover	Aluminum alloy	1
10	Valve guard	Stainless steel	1
9	Discharge valve	Stainless steel	1
8	Suction valve	Stainless steel	1
7	Valve body	Aluminum alloy	1
6	Cylinder tube	Aluminum alloy	1
5	Packing retainer	Aluminum alloy	1
4	Connecting rod	Aluminum alloy	1
3	Bearing retainer	Aluminum alloy	1
2	Crankshaft	Chromium molybdenum steel	1
1	Body	Aluminum alloy	1
Item	Part Name	Material	QTY

38	Product label	-	1
37	Brushless DC motor	-	1
36	Braided tube	Resin	2
35	Axial fan	Aluminum alloy	1
34	Hexagon socket set screw	chromium molybdenum steel	1
33	Shim	Rolled steel Stainless steel	1 or 2
32	Fan finger guard	Steel wire	1
31	Caution label	Resin	1
30	Hexagon socket head cap screw	chromium molybdenum steel	4
29	Hexagon socket head cap screw	chromium molybdenum steel	4
28	Hexagon socket set screw	chromium molybdenum steel	1
27	Hexagon socket set screw	chromium molybdenum steel	1
26	Hexagon socket set screw	chromium molybdenum steel	1
25	Parallel key	Carbon steel	1
24	Parallel key	Carbon steel	1
23	Bearing	Bearing steel	1
22	Bearing	Bearing steel	1
21	Cross recessed binding head screw	Steel wire	4
Item	Part Name	Material	QTY



## 5. Alarm details

The alarm LED will turn on or start to flash when an alarm shown below is generated with the controller. If the cause of the alarm is solved when turning on the power supply again, the alarm LED will turn off and the product will be operable.

Alarm type	Description	LED
Overheating failure (controller)	The internal temperature of the controller exceeded the specified value.	<<Flashing>>
	The internal temperature decreased while the alarm LED was flashing and has cooled enough to allow operation again.	On
Overheating failure (motor)	The internal temperature of the compressor exceeded the specified value.	<<Flashing>>
	The internal temperature decreased while the alarm LED was flashing and has cooled enough to allow operation again.	On
Abnormal power supply voltage	Abnormal power supply voltage for driving the compressor.	On
Overcurrent	The current from the power supply for driving the compressor exceeds the specified value.	On
Overspeed	The motor speed of the compressor exceeds the specified value.	On
Compressor stop time exceeded	The compressor stopped operating and exceeded the specified time limit.	On

### Caution

#### Cautions after an alarm is generated

- 1) The controller and the compressor may be hot when an overheating failure occurs. Pay attention to avoid burns or other injuries.  
It is possible to restart the operation by turning on the power supply again when the temperature is decreased and the alarm LED stops flashing and is constantly turned on.
- 2) The condition of the cables, the connections, or the 24 VDC power supply voltage may be the cause when an alarm for abnormal power supply voltage, excessive voltage, or exceeding compressor stop time is generated. Check the wiring condition and 24 VDC power supply voltage before turning on the power supply again.
- 3) There is a possibility of failure when an alarm is re-displayed after turning on the power supply again. Turn off the power supply immediately. In addition, be aware that there is a risk of failure when the power supply is turned on repeatedly without solving the cause of the alarm.

Phenomenon	Alarm	Possible causes	Countermeasures
The product does not start.	LED ON	Pressure is remaining in the compressor.	- Configure a pneumatic circuit that can release residual pressure. (See section 23) - Check that the solenoid valve for releasing residual pressure is operating normally.
		Incorrect setting of the pressure switch	Check the setting of the pressure switch. (See section 21)
		Incorrect wiring	Check the wiring and connection.
		Power source abnormality, over current, over voltage	Check the wiring and connection. Check that the power source current is satisfying the specifications. In addition, check that there is no failure or other abnormalities.
Overheating failure	LED ON	Increase in ambient temperature such as ambient heat source and sealing.	- Investigate the cause of temperature increase and solve the issue. - Cool it down until the alarm LED starts blinking and turn the power source on again.
Pressure drop	-	Clogging of the silencer	Replace the silencer.
		Deterioration of internal components	The product requires repair because components need to be replaced.
		Water accumulates inside	Mount the compressor at an elevated position of the system. Periodically perform flushing.



### DECLARATION OF INCORPORATION

**SMC Corporation**, 4-14-1, Sotokanda, Chiyoda-ku, Tokyo 101-0021, JAPAN,  
declares under its sole responsibility, that the following equipment:

**Compact Compressor**

**CRP Series (CRP10-□1-□□-□□, CRP10)**

**Batch No. BV onwards Marked H**

1) Is partly completed machinery under the Machinery Directive 2006/42/EC

Name and address of the person authorised to compile the technical file:

Mr Lucio Moriggi, General Manager, SMC Italia S.p.A. Via delle Donne Lavoratrici, 21-20861 BRUGHERIO (MB), ITALY
---

The essential requirements of this Directive as listed below are applied and fulfilled

1.1, 1.2, 1.3, 1.4, 1.5, 1.6, 1.7

The technical documentation for the product listed above was compiled in accordance with part B of Annex VII of the Machinery Directive.

SMC Corporation undertakes to transmit, in response to a reasoned request by the national authorities, relevant information on the partly completed machinery. The method of transmission will be electronic.

The partly completed machinery must not be put into service until the machinery into which it is to be incorporated has been declared in conformity with the provisions of the Directive listed above.

The following standards have been partly applied:

EN 1012-1:2010, EN 1012-2:1996+A1, EN60204-1:2018

For further details please contact SMC.

2) The partly completed machinery referred to above conforms to the EU Directives as listed below:

2014/30/EU [EMC Directive]

2011/65/EU [RoHS Directive]

Please refer to the Declaration of Conformity Document Number CRP-TF123-006EU for details.

Importer/Distributor contact details [www.SMC.eu](http://www.SMC.eu), [www.SMCworld.com](http://www.SMCworld.com)

Tokyo, Date: <DD MMM YYYY>

\_\_\_\_\_  
KENJI SHINOZAKI  
General Manager  
Product Development Division - 4

#### Revision history

- A: -Modify and include individual precautions, specifications, and figures in accordance with CE.  
-Correct pressure switch settings and circuit diagram for vacuum pressure.

## SMC Corporation

4-14-1, Sotokanda, Chiyoda-ku, Tokyo 101-0021 JAPAN

Tel: + 81 3 5207 8249 Fax: +81 3 5298 5362

URL <https://www.smcworld.com>

---

Note: Specifications are subject to change without prior notice and any obligation on the part of the manufacturer.  
© 2023 SMC Corporation All Rights Reserved